

OPERATION AND PARTS MANUAL



Mikasa **SERIES**
MODEL MTX70
TAMPING RAMMER
(HONDA GX100UKRBF GASOLINE ENGINE)

Revision #11 (07/30/10)

To find the latest revision of this
publication, visit our website at:
www.multiquip.com



THIS MANUAL MUST ACCOMPANY THE EQUIPMENT AT ALL TIMES.

 **WARNING** 

CALIFORNIA — Proposition 65 Warning

Engine exhaust and some of its constituents are known to the State of California to cause cancer, birth defects and other reproductive harm.

MTX70 Tamping Rammer

Proposition 65 Warning 2
 Table Of Contents 4
 Parts Ordering Procedures 5
 Safety Information 6-9
 General Information 10
 Specifications 11
 Controls and Components 12
 Basic Engine 13
 Operation 14-16
 Maintenance 17
 Troubleshooting Guide 18-19
 Explanation Of Codes In Remarks Column 20
 Suggested Spare Parts 21
 Name Plate and Decals 22-23
 Crankcase and Engine Assembly 24-27
 Guide Cylinder and Foot Assembly 28-29
 Foot Assembly 30-31
 Tank and Handle Assembly 32-33
 Combination Lever Assembly 34-35
 Tools 36-37

HONDA GX100UKRBF ENGINE

Cylinder Barrel Assembly 38-39
 Crankcase Cover Assembly 40-41
 Crankshaft Assembly 42-43
 Piston Connecting Rod 44-45
 Camshaft Assembly 46-47
 Recoil Starter Assembly 48-49
 Fan Cover Assembly 50-51
 Carburetor Assy (S/N T-3362 and Below) 52-53
 Carburetor Assy (S/N T-3363 and Above) 54-55
 Air Cleaner Assembly 56-57
 Muffler Assembly 58-59
 Flywheel Ignition Assembly 60-61
 Control Assembly 62-63
 Labels Assembly 64-65

Terms and Condition Of Sale — Parts 66



Specification and part number are subject to change without notice.

PARTS ORDERING PROCEDURES

Ordering parts has never been easier! Choose from three easy options:

Effective:
January 1st, 2006

www.multiquip.com



Order via Internet (Dealers Only):

Order parts on-line using Multiquip's SmartEquip website!

- View Parts Diagrams
- Order Parts
- Print Specification Information



If you have an MQ Account, to obtain a Username and Password, E-mail us at: parts@multiquip.com.

To obtain an MQ Account, contact your District Sales Manager for more information.

Goto www.multiquip.com and click on **Order Parts** to log in and save!

Use the **internet** and qualify for a **5% Discount** on *Standard orders* for all orders which include complete part numbers.*

Note: Discounts Are Subject To Change



Order via Fax (Dealers Only):

All customers are welcome to order parts via Fax.

Domestic (US) Customers dial:
1-800-6-PARTS-7 (800-672-7877)

Fax your order in and qualify for a **2% Discount** on *Standard orders* for all orders which include complete part numbers.*

Note: Discounts Are Subject To Change



Order via Phone: Domestic (US) Dealers Call:
1-800-427-1244

Non-Dealer Customers:

Contact your local Multiquip Dealer for parts or call 800-427-1244 for help in locating a dealer near you.



International Customers should contact their local Multiquip Representatives for Parts Ordering information.

When ordering parts, please supply:

- | | |
|---|--|
| <input type="checkbox"/> Dealer Account Number | <input type="checkbox"/> Specify Preferred Method of Shipment: |
| <input type="checkbox"/> Dealer Name and Address | <input checked="" type="checkbox"/> UPS/Fed Ex <input checked="" type="checkbox"/> DHL |
| <input type="checkbox"/> Shipping Address (if different than billing address) | <input type="checkbox"/> Priority One <input checked="" type="checkbox"/> Truck |
| <input type="checkbox"/> Return Fax Number | <input type="checkbox"/> Ground |
| <input type="checkbox"/> Applicable Model Number | <input type="checkbox"/> Next Day |
| <input type="checkbox"/> Quantity, Part Number and Description of Each Part | <input type="checkbox"/> Second/Third Day |

NOTICE

All orders are treated as *Standard Orders* and will ship the same day if received prior to 3PM PST.

WE ACCEPT ALL MAJOR CREDIT CARDS!



Do not operate or service the equipment before reading the entire manual. Safety precautions should be followed at all times when operating this equipment. Failure to read and understand the safety messages and operating instructions could result in injury to yourself and others.



SAFETY MESSAGES

The four safety messages shown below will inform you about potential hazards that could injure you or others. The safety messages specifically address the level of exposure to the operator and are preceded by one of four words: **DANGER**, **WARNING**, **CAUTION** or **NOTICE**.

SAFETY SYMBOLS

! DANGER

Indicates a hazardous situation which, if not avoided, **WILL** result in **DEATH** or **SERIOUS INJURY**.

! WARNING

Indicates a hazardous situation which, if not avoided, **COULD** result in **DEATH** or **SERIOUS INJURY**.







! CAUTION

Indicates a hazardous situation which, if not avoided, **COULD** result in **MINOR** or **MODERATE INJURY**.

NOTICE

Addresses practices not related to personal injury.

Potential hazards associated with the operation of this equipment will be referenced with hazard symbols which may appear throughout this manual in conjunction with safety messages.

Symbol	Safety Hazard
	Lethal exhaust gas hazards
	Explosive fuel hazards
	Burn hazards
	Respiratory hazards
	Accidental starting hazards
	Eye and hearing hazards

GENERAL SAFETY

CAUTION

- **NEVER** operate this equipment without proper protective clothing, shatterproof glasses, respiratory protection, hearing protection, steel-toed boots and other protective devices required by the job or city and state regulations.



- **NEVER** operate this equipment when not feeling well due to fatigue, illness or when under medication.



- **NEVER** operate this equipment under the influence of drugs or alcohol.



- **ALWAYS** check the equipment for loosened threads or bolts before starting.
- **DO NOT** use the equipment for any purpose other than its intended purposes or applications.

NOTICE

- This equipment should only be operated by trained and qualified personnel 18 years of age and older.
- Whenever necessary, replace nameplate, operation and safety decals when they become difficult read.
- Manufacturer does not assume responsibility for any accident due to equipment modifications. Unauthorized equipment modification will void all warranties.
- **NEVER** use accessories or attachments that are not recommended by Multiquip for this equipment. Damage to the equipment and/or injury to user may result.
- **ALWAYS** know the location of the nearest fire extinguisher.
- **ALWAYS** know the location of the nearest first aid kit.



- **ALWAYS** know the location of the nearest phone or **keep a phone on the job site**. Also, know the phone numbers of the nearest **ambulance, doctor** and **fire department**. This information will be invaluable in the case of an emergency.

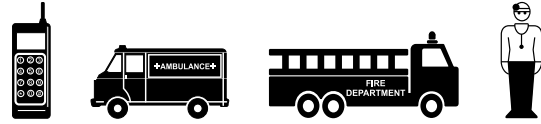

RAMMER SAFETY

DANGER

- **NEVER** operate the equipment in an explosive atmosphere or near combustible materials. An explosion or fire could result causing severe **bodily harm or even death**.



WARNING

- **NEVER** disconnect any **emergency or safety devices**. These devices are intended for operator safety. Disconnection of these devices can cause severe injury, bodily harm or even death. Disconnection of any of these devices will void all warranties.
- **DO NOT** use this machine on ground that is harder than the machine can handle, or for driving pilings or tamping rock beds. Furthermore, use of the machine on sloping ground, such as the side of an embankment, may make the machine unstable and can cause an accident. It can also result in premature machine wear due to uneven loads on the machine.

Use the machine with confidence for tamping earth and sand, soil, gravel, and asphalt. **DO NOT** use the machine for other types of jobs.

CAUTION

- **NEVER** lubricate components or attempt service on a running machine.

NOTICE

- **ALWAYS** keep the machine in proper running condition.
- Fix damage to machine and replace any broken parts immediately.
- **ALWAYS** store equipment properly when it is not being used. Equipment should be stored in a clean, dry location out of the reach of children and unauthorized personnel.

ENGINE SAFETY

DANGER

- The engine fuel exhaust gases contain poisonous carbon monoxide. This gas is colorless and odorless, and can cause death if inhaled.
- The engine of this equipment requires an adequate free flow of cooling air. **NEVER** operate this equipment in any enclosed or narrow area where free flow of the air is restricted. If the air flow is restricted it will cause injury to people and property and serious damage to the equipment or engine.



WARNING

- **DO NOT** place hands or fingers inside engine compartment when engine is running.
- **NEVER** operate the engine with heat shields or guards removed.
- **DO NOT** remove the engine oil drain plug while the engine is hot. Hot oil will gush out of the oil tank and severely scald any persons in the general area of the rammer.



CAUTION

- **NEVER** touch the hot exhaust manifold, muffler or cylinder. Allow these parts to cool before servicing equipment.



NOTICE

- **NEVER** run engine without an air filter or with a dirty air filter. Severe engine damage may occur. Service air filter frequently to prevent engine malfunction.
- **NEVER** tamper with the factory settings of the engine or engine governor. Damage to the engine or equipment can result if operating in speed ranges above the maximum allowable.



FUEL SAFETY

DANGER

- **DO NOT** add fuel to equipment if it is placed inside truck bed with plastic liner. Possibility exists of explosion or fire due to static electricity.

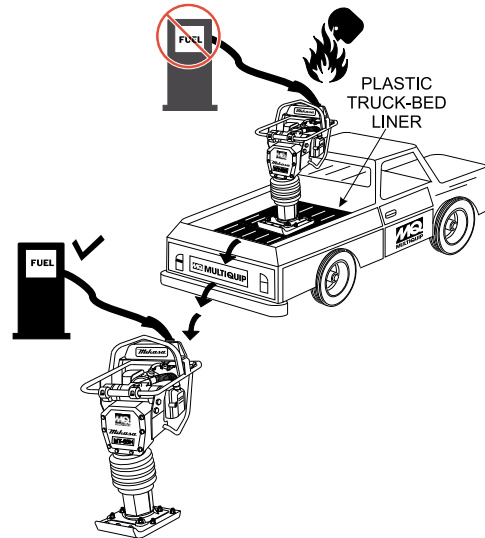

- **DO NOT** start the engine near spilled fuel or combustible fluids. Fuel is extremely flammable and its vapors can cause an explosion if ignited.
- **ALWAYS** refuel in a well-ventilated area, away from sparks and open flames.
- **ALWAYS** use extreme caution when working with flammable liquids.
- **DO NOT** fill the fuel tank while the engine is running or hot.
- **DO NOT** overfill tank, since spilled fuel could ignite if it comes into contact with hot engine parts or sparks from the ignition system.
- Store fuel in appropriate containers, in well-ventilated areas and away from sparks and flames.
- **NEVER** use fuel as a cleaning agent.
- **DO NOT** smoke around or near the equipment. Fire or explosion could result from fuel vapors or if fuel is spilled on a hot engine.



TRANSPORTING SAFETY

CAUTION

- NEVER allow any person or animal to stand underneath the equipment while lifting.

NOTICE

- Before lifting, make sure that the equipment parts (hook and vibration insulator) are not damaged and screws are not loose or missing.
- Always make sure crane or lifting device has been properly secured to the lifting bail (hook) of the equipment.
- **ALWAYS** shutdown engine before transporting.
- **NEVER** lift the equipment while the engine is running.
- Tighten fuel tank cap securely and close fuel cock to prevent fuel from spilling.
- Use adequate lifting cable (wire or rope) of sufficient strength.
- Use one point suspension hook and lift straight upwards.
- **DO NOT** lift machine to unnecessary heights.
- **ALWAYS** tie down equipment during transport by securing the equipment with rope.
- Never allow any person or animal to stand underneath the equipment while lifting.

ENVIRONMENTAL SAFETY

NOTICE

- Dispose of hazardous waste properly. Examples of potentially hazardous waste are used motor oil, fuel and fuel filters. 
- **DO NOT** use food or plastic containers to dispose of hazardous waste.
- **DO NOT** pour waste, oil or fuel directly onto the ground, down a drain or into any water source.

Definition of Tamping Rammer

The Mikasa MTX70 tamping rammer is a powerful compacting tool capable of applying a tremendous force in consecutive impacts to a soil surface. Its applications include soil compacting for road, embankments and reservoirs as well as backfilling for gas pipelines, water pipelines and cable installation work.

The impact force of the MTX70 levels and uniformly compacts voids between soil particles to increase dry density.

Circular motion is converted to create impact force. The MTX70 tamping rammer develops a powerful compacting force at the foot of the rammer. To maintain optimum performance, proper operation and service are essential.

The Mikasa MTX70 is equipped with an air cooled, four-cycle gasoline engine. Transmission of the power takes place by increasing the engine speed to engage the centrifugal clutch.

The Mikasa MTX70 uses an oil bath lubrication system. Always check the oil level through the oil level sight glass at the rear of the tamper foot.

Before starting the MTX70 Tamping Rammer identify and understand the function of the controls.

CAUTION

Handle Operation



Before starting operation check the lifting handle to:

1. Make sure that there is no damage on the bolts.
2. Make sure that there is no crack or breakage on handle.
3. Make sure that there is no fissure on the surface. If there is any abnormality or damage, replace with new one.

For operation:

This handle is to be used to lift up the shoe part of the machine with the body laid down on the ground or truck bed.

1. Use proper lifting techniques to avoid back injury. This handle is for manual lifting only.
2. Do not use this handle as a rammer lift point. Use the lifting point on the top of the machine.
3. Do not move the rammer with the lifting handle and the front rollers more than 16 feet (5 meters).

Table 1. MTX-70 Rammer Specifications

Overall Height	39.37 in. (1000 mm)
Overall Width	13.78 in (350 mm)
Over Length	31.02 in (788 mm)
Shoe Size	13.4 x 11.2 (340 x 285 mm)
Fuel Tank Capacity	3.2 qt. (3 liters)
Lubrication Oil Capacity	0.8 quart (0.75 liter)
No. of Impacts Per Second	10.7 - 11.5
Impact Force	2,855 lb (12.7 kN)
Impact Plate Stroke	2 -3.15 in (50 - 80 mm)
Operating Weight	165.34 lbs. (75 kg)
Measured Sound Power Level	104 dB
Guaranteed Sound Power Level	107 dB
Max. Sound Pressure Level	94 dB

Table 2. Engine Specifications

Model	Honda GX100UKRBF Engine
Type	Air-Cooled 4 Stroke, Overhead camshaft, single cylinder gasoline engine
Piston Displacement	6.0 cu.in. (98 cc)
Max. Output	3.0 hp/3,600 rpm (2.2 KW)
Max. Governed Speed, No Load	3,800 - 4,100 rpm
Cooling System	Air-Cooled
Engine Oil Capacity	0.3 qt. (0.28 liters)
Fuel	Unleaded gasoline
Lubricant for Engine	Automobile Oil; Class SE or higher
Starting System	Recoil Starter
Spark Plug Type	NGK CR5HSB



Specifications are general and are subject to change without notice. If exact measurements are required, equipment should be weighed and measured.

MTX70 — CONTROLS AND COMPONENTS

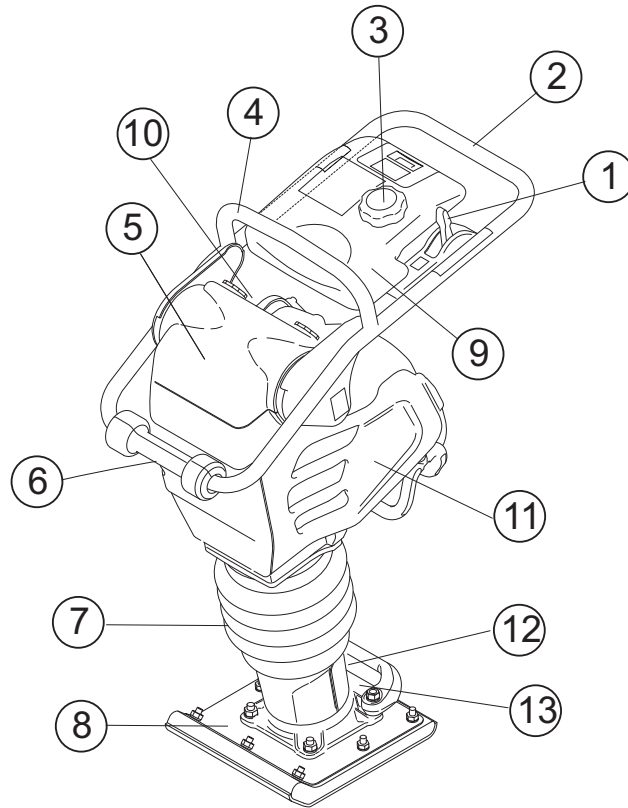

Figure 1. MTX70 Rammer

Figure 1 shows the location of the controls and components for the MTX70 Tamping Rammer. The functions of each control is described below:

1. **Combination (Throttle) Lever** – Used to adjust engine speed (rpm). Move lever forward (**SLOW**) to reduce engine speed, move lever back toward operator (**FAST**) to increase speed. Always operate the rammer at full speed (rpm).
2. **Handle** – To operate rammer, **GRIP** handle assembly firmly on both sides.
3. **Fuel Tank Cap** – Remove this cap to add unleaded gasoline to the fuel tank. Make sure cap is tightened securely. **DO NOT** over fill.
4. **Hook** – Used to lift rammer for transporting.
5. **Air Cleaner Cover** – Protects the air cleaner which prevents dirt and other debris from entering the engine.
6. **Roller** – Allows rammer to be moved around easily by rolling the unit.
7. **Bellows** – Reservoir for oil bath.
8. **Foot** – Laminated wood with tempered steel plate for superior shock absorption.
9. **Fuel Tank** – Holds the fuel for the unit (up to 3.2 quarts)
10. **Muffler** – reduces the noise of the engine when running.
11. **Engine** – this unit uses a Honda GX100UKRBF gasoline engine.
12. **Oil Gauge (Sight Glass)** – Indicates the level of oil in the oil bath reservoir.
13. **Drain Valve** – Open this valve to remove oil from the bellows.



WARNING

Adding fuel to the tank should be accomplished only when the engine is stopped and has had an opportunity to **cool down**. In the event of a fuel spill, **DO NOT** attempt to start the engine until the fuel residue has been completely wiped up, and the area surrounding the engine is dry.

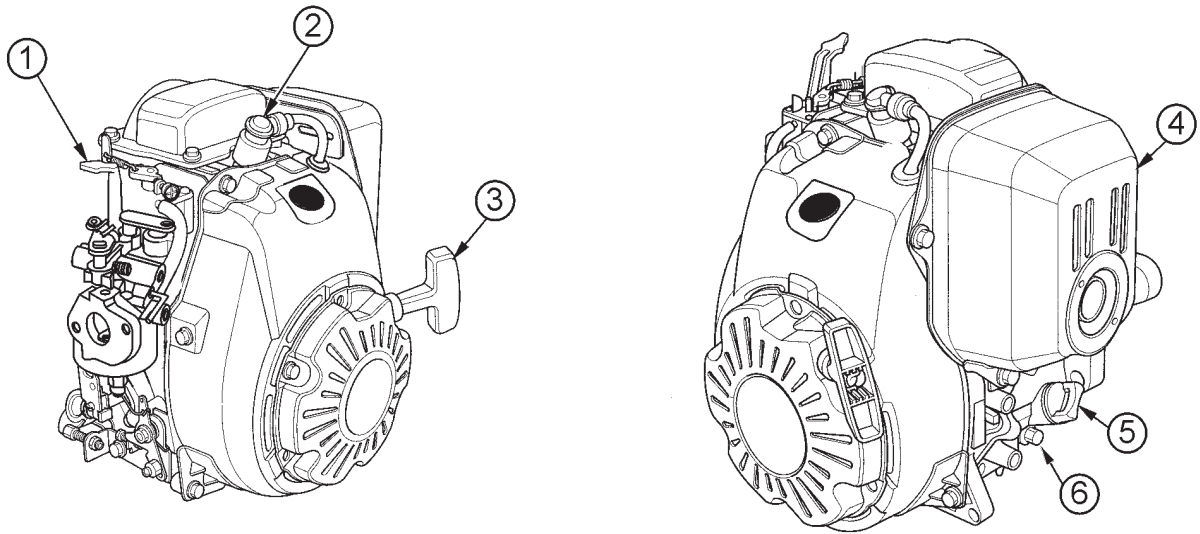

**Figure 1A. Engine Controls and Components
(Honda GX100)**

INITIAL SERVICING

The engine (Figure 1A) must be checked for proper lubrication and filled with fuel prior to operation. Refer to the manufacturers Engine manual for instructions & details of operation and servicing.

1. **Choke Lever** –Used when starting the engine. Normally used in cold weather conditions. In cold weather turn the choke lever to the fully closed position, in warm weather set choke lever half way or completely open.
2. **Spark Plug** – Provides spark to the ignition system. Set spark plug gap to 0.024 - 0.028 inch (0.6 - 0.7 mm). Clean spark plug once a week.
3. **Recoil Starter (pull rope)** – Manual-starting method. Pull the starter grip until resistance is felt, then pull briskly and smoothly.



Operating the engine without an air filter, with a damaged air filter, or a filter in need of replacement will allow dirt to enter the engine, causing rapid engine wear.

4. **Muffler** – Used to reduce noise and emissions.



WARNING

Engine components can generate extreme heat. To prevent burns, **DO NOT** touch these areas while the engine is running or immediately after operating. **NEVER** operate the engine with the muffler removed.

5. **Dipstick/Oil Filler Cap** – Remove this cap to determine if the engine oil is low. Add oil through this filler port as recommended in Table 3.
6. **Oil Drain Plug** – Remove this plug to remove oil from the engine's crankcase.

This section is intended to assist the operator with the initial start-up of the MTX70 Tamping Rammer. It is extremely important that this section be read carefully before attempting to operate the rammer.

DO NOT use your rammer until this section is thoroughly understood.

CAUTION

Failure to understand the operation of the MTX70 Tamping Rammer could result in severe damage to the unit or personal injury.

Rammer Crankcase and Spring Cylinder Oil Bath

This unit uses an oil bath lubrication system. Perform the following:

1. Check the oil level through the oil level sight glass (Figure 2) at the rear of the tamper foot.

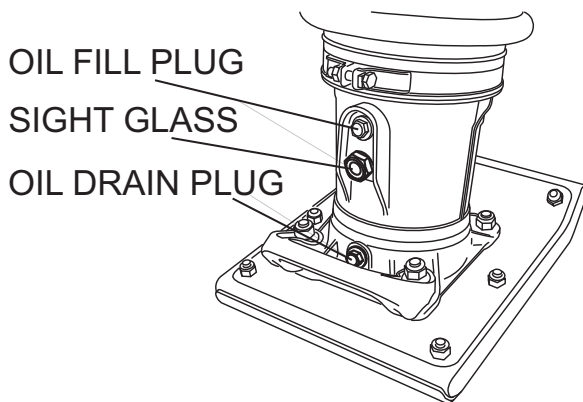

Figure 2. Foot Housing Sight Glass

2. If oil is not visible, add 10W-30 SE, SF or higher grade motor oil into the oil fill plug opening (Figure 2). The bath contains approximately 1.7 pints (800 cc.)



The oil level should be kept at the half way point of the sight glass.

Engine

1. Fill the fuel tank (Figure 3) with unleaded gasoline. At the same time, check the engine oil and make it a habit to replenish it often (Figure 4).

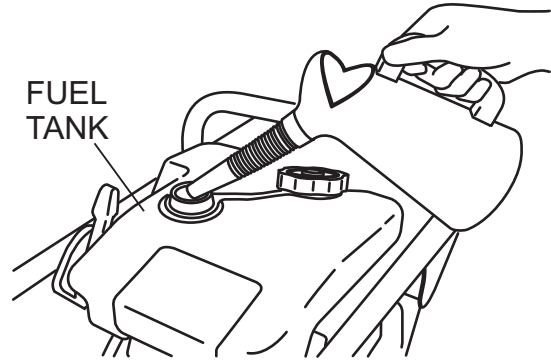

Figure 3. Fuel Tank

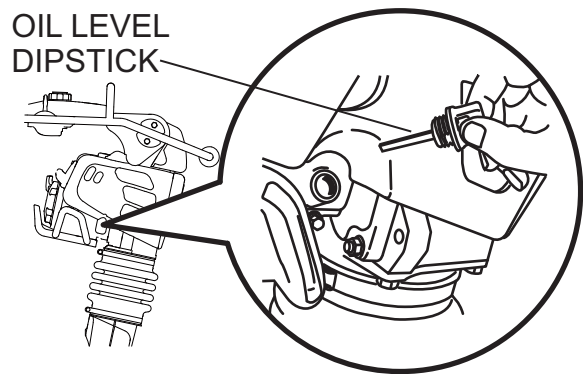

Figure 4. Engine Oil Dipstick

2. Low levels of oil may result in engine seizure due to high levels of consumption during operations.
3. Check the engine oil level and if the engine oil level is low, it should be refilled. Use the proper motor oil as suggested in the Table 3 below.

Table 3 Motor Oil Grade

Season or Temperature	Grade of motor oil (higher than MS class)
Spring, Summer or Autumn +120° F to +15° F	SAE 30
Winter +40° F to +15° F	SAE 30
Below +15° F	SAE 10W-30

Inspection

1. Check all nuts, bolts fasteners for tightness. Retighten as necessary.
2. Clean any dirt from the recoil starter and foot pedestal. Wipe the entire unit clean before operating.
3. Replace any missing or damaged Safety Operation decals.
4. Adjust height of handle. Adjust handle by loosening nuts and moving handle to suit operation. Retighten nuts.

Initial Start-up

When starting the MTX70 Tamping Rammer perform the following:

1. Slide the throttle lever from the stop to the idle position (🐿) (Figure 5). This opens the fuel cock and the engine electrical circuit is turned on automatically.

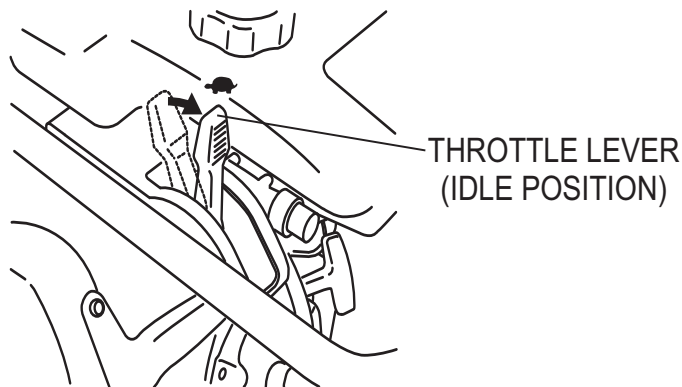

Figure 5-A. Throttle Lever (Idle Position)

2. **Units with Carburetor Primer System:** Push the primer pump bulb four (4) times to deliver fuel to the carburetor (Figure 5-B).

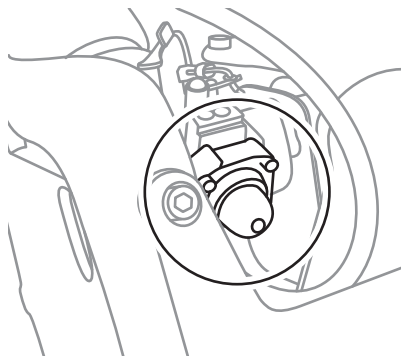
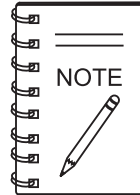

Figure 5-B. Primer Pump



DO NOT press the primer pump bulb more than four (4) times, as this will cause fuel to flood the carburetor.

3. Place the choke lever to the closed position. When the weather is cold, close the choke all the way. When it is hot, or if the engine is hot, open the choke a little or leave it fully open.

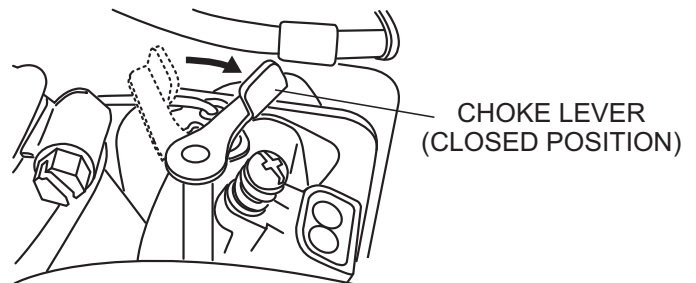

Figure 6. Choke Lever

4. Grip the starter rope handle (Figure 7 handle and pull it until you feel a slight resistance. Then pull sharply and quickly. Return the handle to the starter case before releasing.

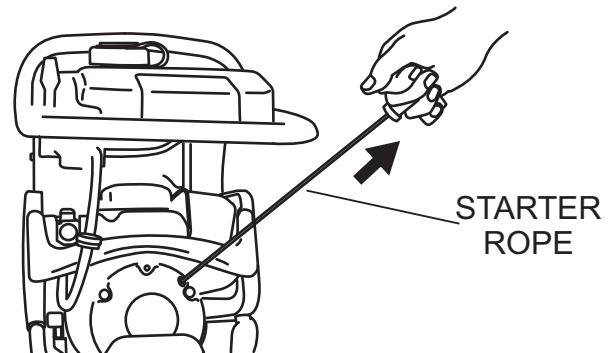

Figure 7. Recoil Starter

5. If engine fails to start, move the choke lever (Figure 6) to the half open position to avoid flooding.
6. Repeat steps 1 thru 5.
7. If the engine does not start after repeated attempts, check the spark plug for excess fuel. Clean and replace the spark plug as needed.

Operation

1. To start the rammer tamping action, move the throttle lever (Figure 8) **quickly** from **IDLE** to the **START** (↶) position. **DO NOT** move the throttle lever slowly as this may cause damage to the clutch or spring.

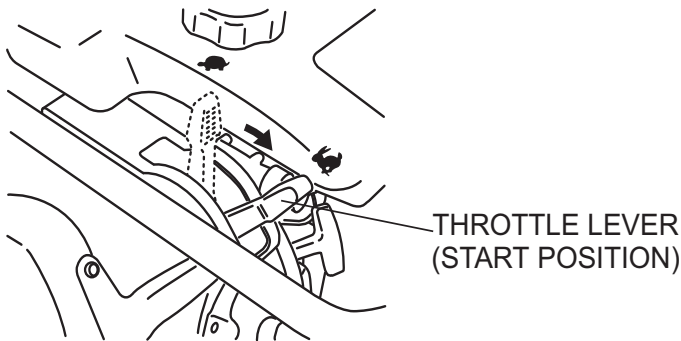

Figure 8. Throttle Lever (Start Position)

CAUTION

Make sure that the throttle lever is moved to the **FULL START** position. Operating the rammer at less than full speeds can result in damage to the clutch springs or foot.

2. The MTX70 tamping rammer is designed to run at 3,800 to 4,100 rpm. At optimum rpm the foot hits at the rate between 590 ~ 695 impacts per minute. Increasing throttle speed past factory set rpm does not increase impacts and may damage unit. The MTX70 is designed to advance while tamping. For faster advance, pull back slightly on the handle so that rear of foot contacts soil first.
3. To stop the tamping action, move throttle lever quickly from **START** to **IDLE** position (Figure 9).

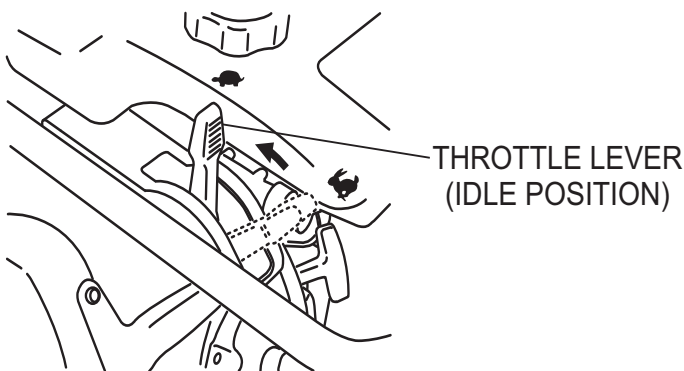

Figure 9. Throttle Lever (Idle Position)

Stopping The Engine

Normal Shutdown

1. Move throttle lever quickly from the **START** to **IDLE** position (Figure 9) and run the engine for three minutes at low speed. After the engine **cools**, move the throttle lever to the **STOP** position (Figure 10). The engine will stop and the fuel cock is automatically closed.

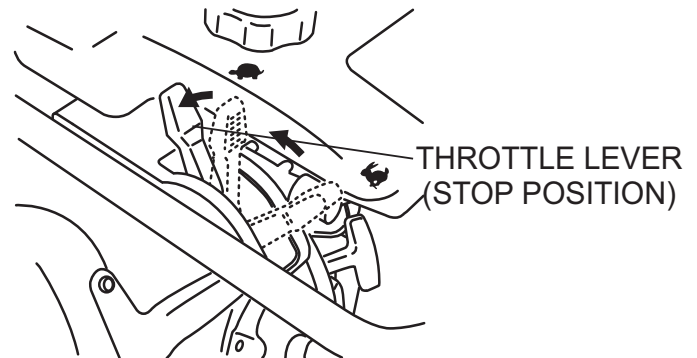

Figure 10. Throttle Lever (Stop Position)

2. If the engine does not stop due to a problem with the switch or the like, move the machine to a safe location and hold the throttle lever in the stop position. Let the machine run on idle and the machine will stop after a few minutes.

Maintenance

Perform the scheduled maintenance procedures as indicated:

DAILY

- Thoroughly remove dirt and oil from the engine and control area.
- Clean or replace the air cleaner elements as necessary. Check and retighten all fasteners as necessary.
- Check the spring box and bellows for oil leaks. Repair or replace as needed.

EVERY 50 HOURS

- Remove the fuel filter cap and clean the inside of the fuel tank (Figure 11).

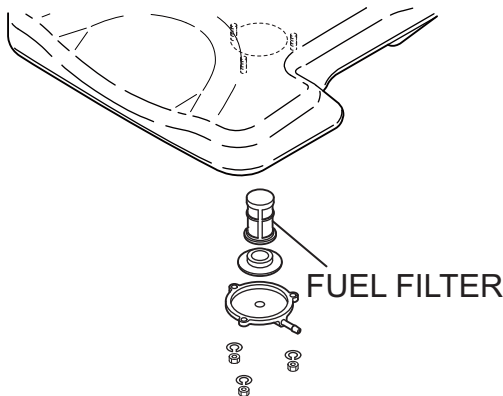

Figure 11. Fuel Filter

- Remove and clean the spark plug, then adjust the spark gap to 0.024~0.028 inch (0.6~0.7 mm).

EVERY 80 to 100 HOURS

- Remove the air cleaner cover. Loosen and remove the 2 screws that hold the cover to the air cleaner assembly. If the primary element (Figure 12) is dirty, wash it with gasoline or kerosene. Then dip it in engine oil (SAE 10W-30) and wring the element so that 25 to 30 cc of engine oil remains on the element.

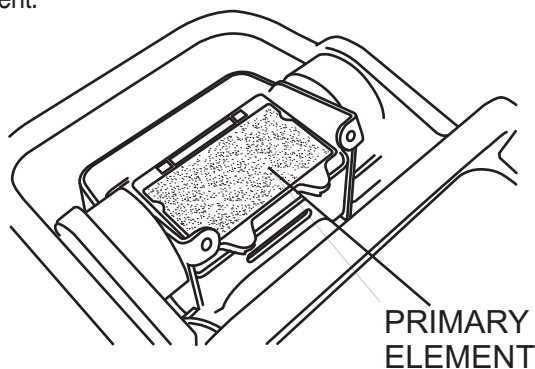

Figure 12. Air Cleaner Primary Element

EVERY 200 HOURS

- Remove the oil drain plug on foot housing (Figure 13) and drain the oil. Refill with approximately 1.7 pt. (800 cc.) of 10W-30 SE, SF or higher grade motor oil. Oil should be midway in sight glass. Break in oil should be changed after first 50 hours.

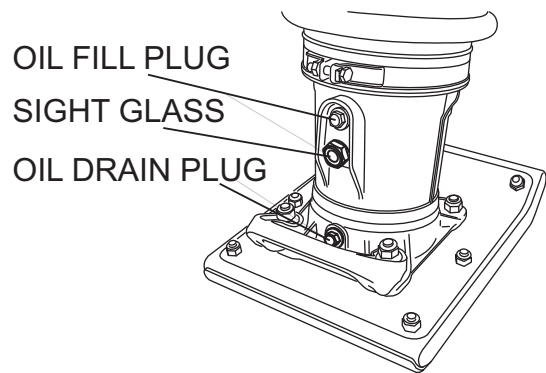

Figure 13. Oil Drain Plug

EVERY 2 YEARS

- Replace the fuel line every 2 years even if there is no visible damage.

Long Term Storage

- Slide the throttle lever to the STOP position.
- Drain any fuel including in the fuel hose.
- Replace lubrication oil and apply grease to lubrication points.
- Cover the air intake on the air cleaner and the exhaust outlet on the muffler.
- Store unit indoors covered with plastic sheet in moisture free and dust free location out of direct sunlight.

MTX70 — TROUBLESHOOTING GUIDE

TABLE 4. ENGINE TROUBLESHOOTING

SYMPTOM	POSSIBLE PROBLEM	SOLUTION
Difficult to start		
Fuel is available but spark plug will not ignite. (Power available at high tension cable).	Ignition plug being bridge?	Check ignition system.
	Carbon deposit at ignition?	Clean or replace ignition.
	Short circuit due to defective insulators?	Replace insulators.
	Improper spark gap?	Set spark plug gap to the correct gap.
Fuel is available but spark plug will not ignite. (Power NOT available at high tension cable).	Short circuit at stop switch?	Check stop switch circuit. Replace stop switch if defective.
	Ignition coil defective?	Replace ignition coil.
Fuel is available and spark plug ignites (compression normal).	Muffler clogged with carbon deposits?	Clean or replace muffler.
	Fuel in use inadequate (water, dust)?	Flush fuel sytem and replace with fresh fuel.
	Air Cleaner clogged?	Clean or replace air cleaner.
Fuel is available and spark plug ignites (compression low).	Cylinder worn?	Replace cylinder.
	Spark plug loose?	Tighten spark plug.
Low compression.	Incorrect valve adjustment?	Check and adjust valves.
Operation not satisfactory		
Not enough power available (compression normal, no miss-firing).	Air cleaner clogged?	Clean or replace air cleaner.
	Air in fuel line?	Bleed (remove air) from fuel line.
	Carbon deposits in cylinder?	Clean or replace cylinder
Not enough power available (compression normal, miss-firing).	Ignition coil defective?	Flush fuel sytem and replace with fresh fuel.
	Ignition plug often shorts?	Replace ignition wires, clean ignition.
	Fuel in use inadequate (water, dust)?	Flush fuel sytem and replace with fresh fuel.
Engine overheats.	Excessive carbon depostion in combustion chamber?	Clean or replace crankcase.
	Exhaust or muffler clogged with carbon.	Clean or replace muffler.
	Spark plug heat value incorrect?	Replace spark plug with correct type spark plug.
Engine high speed incorrect.	Incorrect engine RPM?	Check and adjust engine RPM to 3900-4100 RPM.

MTX70 — TROUBLESHOOTING GUIDE

TABLE 4. ENGINE TROUBLESHOOTING (continued)

SYMPTOM	POSSIBLE PROBLEM	SOLUTION
Operation not satisfactory		
Rotational speed fluctuates.	Governor adjustment improper?	Adjust governor to correct lever.
	Governor spring defective?	Clean or replace ignition.
	Fuel flow erratic?	Check fuel line.
	Air taken in through suction line?	Check suction line.
Recoil starter not working properly.	Dust in rotating part?	Clean recoil starter assembly.
	Spring spring failure?	Replace sprial spring.

TABLE 5. RAMMER TROUBLESHOOTING

SYMPTOM	POSSIBLE PROBLEM	SOLUTION
Engine runs but rammer jumps erratically or not at all..	Operating speed of throttle lever is incorrectly set?	Set throttle lever to correct position.
	Oil in excess?	Drain excess oil. Bring to correct level.
	Clutch slips?	Replace or adjust clutch.
	Spring Failure?	Replace sprial spring.
	Speed of engine improper?	Adjust engine speed to correct operating RPM setting.
	Soil over-compacted?	Shut-down machine and test soil.

MTX70—EXPLANATION OF PARTS SECTION REMARKS

The following section explains the different symbols and remarks used in the Parts section of this manual. Use the help numbers found on the back page of the manual if there are any questions.

NOTICE

The contents and part numbers listed in the parts section are subject to change **without notice**. Multiquip does not guarantee the availability of the parts listed.

SAMPLE PARTS LIST

NO.	PART NO.	PART NAME	QTY.	REMARKS
1	12345	BOLT.....	1	INCLUDES ITEMS W/%
2%		WASHER, 1/4 IN.....		NOT SOLD SEPARATELY
2%	12347	WASHER, 3/8 IN....	1	MQ-45T ONLY
3	12348	HOSE		A/R ...MAKE LOCALLY
4	12349	BEARING	1	S/N 2345B AND ABOVE

NO. Column

Unique Symbols — All items with same unique symbol

(@, #, +, %, or >) in the number column belong to the same assembly or kit, which is indicated by a note in the “Remarks” column.

Duplicate Item Numbers — Duplicate numbers indicate multiple part numbers, which are in effect for the same general item, such as different size saw blade guards in use or a part that has been updated on newer versions of the same machine.

NOTICE

When ordering a part that has more than one item number listed, check the remarks column for help in determining the proper part to order.

PART NO. Column

Numbers Used — Part numbers can be indicated by a number, a blank entry, or TBD.

TBD (To Be Determined) is generally used to show a part that has not been assigned a formal part number at the time of publication.

A blank entry generally indicates that the item is not sold separately or is not sold by Multiquip. Other entries will be clarified in the “Remarks” Column.

QTY. Column

Numbers Used — Item quantity can be indicated by a number, a blank entry, or A/R.

A/R (As Required) is generally used for hoses or other parts that are sold in bulk and cut to length.

A blank entry generally indicates that the item is not sold separately. Other entries will be clarified in the “Remarks” Column.

REMARKS Column

Some of the most common notes found in the “Remarks” Column are listed below. Other additional notes needed to describe the item can also be shown.

Assembly/Kit — All items on the parts list with the same unique symbol will be included when this item is purchased.

Indicated by:

“INCLUDES ITEMS W/(unique symbol)”

Serial Number Break — Used to list an effective serial number range where a particular part is used.

Indicated by:

“S/N XXXXX AND BELOW”

“S/N XXXX AND ABOVE”

“S/N XXXX TO S/N XXX”

Specific Model Number Use — Indicates that the part is used only with the specific model number or model number variant listed. It can also be used to show a part is NOT used on a specific model or model number variant.

Indicated by:

“XXXXX ONLY”

“NOT USED ON XXXX”

“Make/Obtain Locally” — Indicates that the part can be purchased at any hardware shop or made out of available items. Examples include battery cables, shims, and certain washers and nuts.

“Not Sold Separately” — Indicates that an item cannot be purchased as a separate item and is either part of an assembly/kit that can be purchased, or is not available for sale through Multiquip.

MTX70 RAMMER 1 TO 3 UNITS WITH HONDA GX100UKRBF ENGINE

Qty.	P/N	Description
1	956100062	THROTTLE WIRE
3	366010070	SECONDARY ELEMENT, AIR CLEANER
3	366010080	PRIMARY ELEMENT, AIR CLEANER
1	366900020	CAP, FUEL TANK W/ STRAP
2	16910Z4ES21 ..	FILTER, IN-LINE FUEL
3	9805655757	SPARK PLUG
1	959300770	STRAINER, FUEL TANK
1	28462Z0DV02 ..	ROPE, RECOIL STARTER

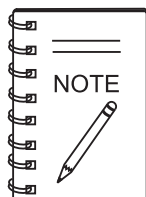

Part numbers on this Suggested Spare Parts List may supersede/replace the P/N shown in the text pages of this book.

MTX70— NAMEPLATE AND DECALS

NAME PLATE AND DECALS

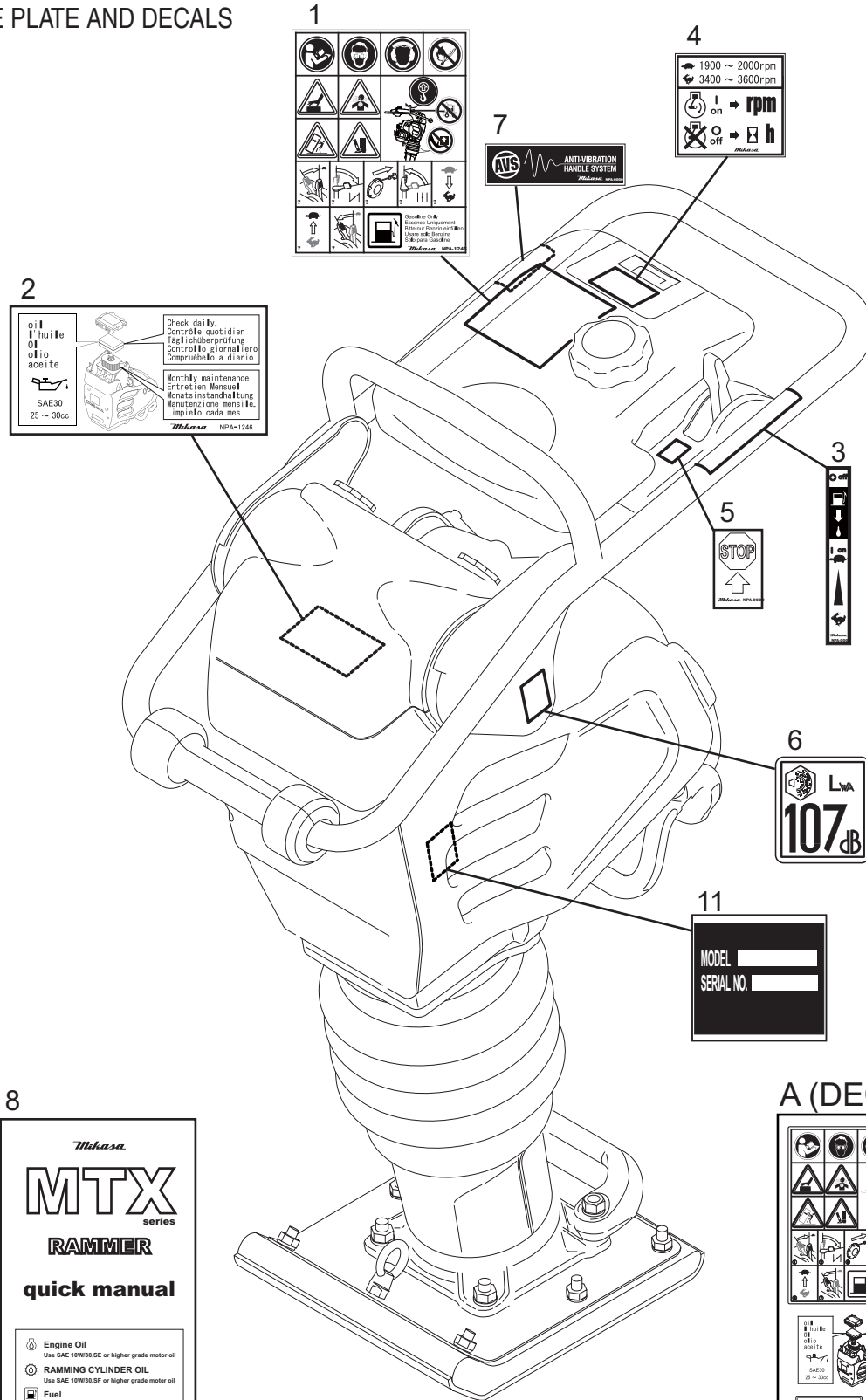

2

oil	huile	<p>Check daily. Contrôle quotidien Tägliche Überprüfung Controllo giornaliero Compruebe lo a diario</p> <p>Monthly maintenance Entretien Mensuel Monatsinsandhaltung Manutenzione mensile Limpeza cada mes</p> <p><i>Mikasa</i> NPA-1248</p>
oil	aceite	
SAE30	25 ~ 30cc	

8

Mikasa

MTX

series

RAMMER

quick manual

Engine Oil
Use SAE 10W30, SE or higher grade motor oil

RAMMING CYLINDER OIL
Use SAE 10W30, SF or higher grade motor oil

Fuel
Use normal quality gasoline

A (DECAL SET)

TAMMING RAMMER / MTX *Mikasa* S38003140

MTX70— NAMEPLATE AND DECALS

NAME PLATE AND DECALS

<u>NO</u>	<u>PART NO</u>	<u>PART NAME</u>	<u>QTY.</u>	<u>REMARKS</u>
A	920900040	DECAL SET	1	INCLUDES ITEMS W/ #
1#		DECAL: OPERATION	1	
2#		DECAL: AIR CLEANER	1	
3#		DECAL: LEVER OPERATION	1	
4#		DECAL: MAX SPEED	1	
5#		DECAL: MACHINE STOP	1	
6#		DECAL: EC NOISE REQ	1	
7#		DECAL: ANTI-VIB HANDLE	1	
8	920212540	QUICK MANUAL	1	
11		DECAL: NAMEPLATE	1	CONTACT MQ PARTS DEPT W/ SERIAL NO.

MTX70 — CRANKCASE AND ENGINE ASSY.

CRANKCASE AND ENGINE ASSY.

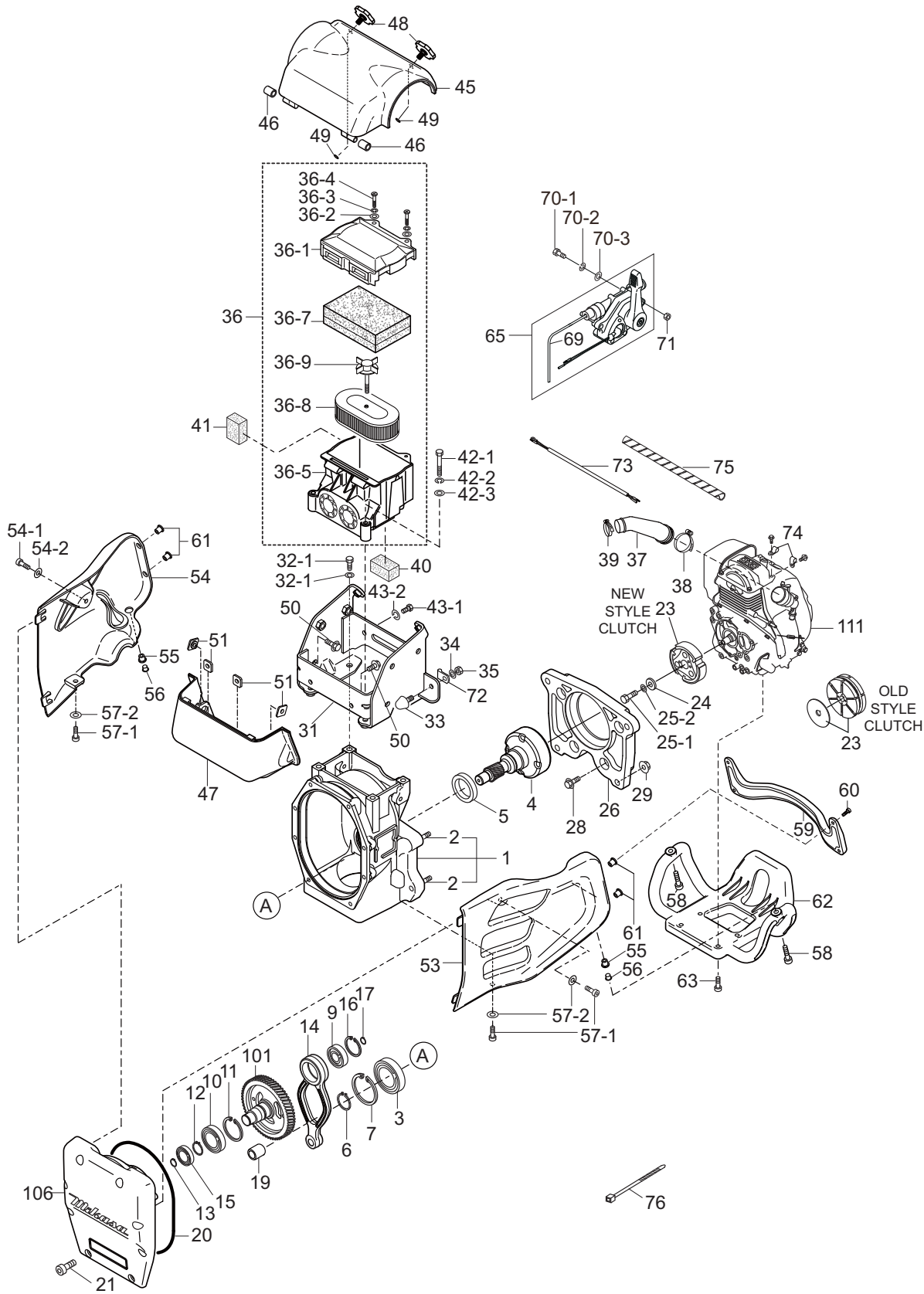

MTX70 — CRANKCASE AND ENGINE ASSY.

CRANKCASE AND ENGINE ASSY.

<u>NO.</u>	<u>PART NO.</u>	<u>PART NAME</u>	<u>QTY.</u>	<u>REMARKS</u>
1	366910010	CRANK CASE	1	INCLUDES ITEMS W/ \$
2\$	009120204	STUD BOLT 10 X 30	4	
3	041006007	BEARING 6007Z	1	
4	366345170	DRUM, PINION	1	
5	060404010	OIL SEAL TC-40528	1	
6	080200350	STOP RING S-35	1	
7	080100620	STOP RING R-62	1	
9	040006207	BEARING 6207	1	
10	040006305	BEARING 6305	1	
11	080100720	STOP RING R-72	1	
12	080200350	STOP RING S-35	1	
13	080200250	STOP RING S-25	1	
14	366345230	CONNECTING ROD	1	
15	040006304	BEARING 6304	1	
16	080100520	STOP RING R-52	1	
17	080200200	STOP RING S-20	1	
19	047940060	NEEDLE BEARING FJ-1816	1	
20	050710080	O-RING	1	
21	001520825	SOCKET HEAD BOLT 8X25 T	8	
23	366346210	CLUTCH ASSY	1	S/N S-1390 AND BELOW
23	366348550	CLUTCH ASSY	1	S/N S-1391 AND ABOVE
24	952401450	WASHER, 5X22X3	1	
25-1	001220825	BOLT 8X25 T	1	
25-2	030208200	WASHER, LOCK M8	1	
26	366217180	FLANGE, ENGINE	1	
28	001710830	FLANGE BOLT 8X30	4	
29	022611010	FLANGE NUT M10	4	
31	366346280	BRACKET, SHOCK ABSORBER	1	
32-1	001211030	BOLT 10X30	4	
32-2	030210250	WASHER, LOCK M10	4	
33	939010270	STOPPER RUBBER (70)	1	
34	030208200	WASHER, LOCK M8	1	
35	020308060	NUT M8	1	
36	366900010	CRANKCASE CP	1	INCLUDES ITEMS W/ #
36-1#	366010010	AIR CLEANER COVER CP	1	
36-2#	366010020	WASHER, FLAT M6	2	
36-3#	366010030	WASHER, LOCK M6	2	
36-4#	366010040	COIN BOLT M6	2	
36-5#	366010050	BASE CP, AIR CLEANER	1	
36-7#	366010070	PRIMARY ELEMENT CP	1	
36-8#	366010080	SECONDARY ELEMENT	1	
36-9#	366030040	GRIP BELT CP	1	
37	366345470	PIPE, INTAKE	1	
38	954407681	CYCLONE CLAMP (CY-1) 45	1	
39	954407682	CYCLONE CLAMP (CY-1) 38	1	
40	366460160	SEALING FORM, UNDER	1	
41	366460150	SEALING FORM, SIDE	1	

MTX70 — CRANKCASE AND ENGINE ASSY.

CRANKCASE AND ENGINE ASSY.

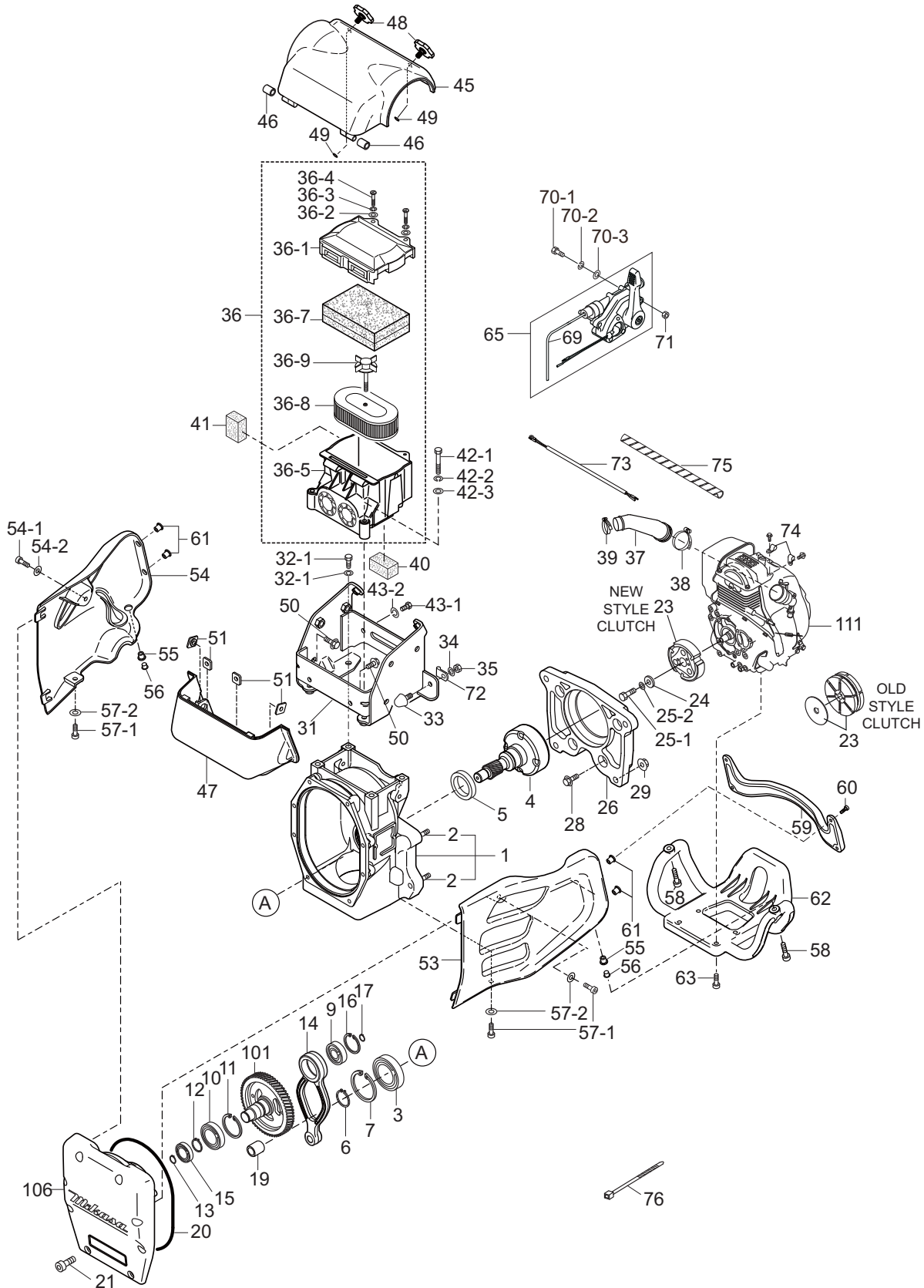

MTX70 — CRANKCASE AND ENGINE ASSY.

CRANKCASE AND ENGINE ASSY.

<u>NO.</u>	<u>PART NO.</u>	<u>PART NAME</u>	<u>QTY.</u>	<u>REMARKS</u>
42-1	001220851	BOLT 8X55 T	2	
42-2	030208200	WASHER, LOCK M8	2	
42-3	031108160	WASHER, FLAT M8	2	
43-1	001210815	BOLT 8X15	2	
43-2	030208200	WASHER, LOCK M8	2	
45	366217340	COVER, CLEANER (UPPER)	1	
46	366460140	RUBBER BUSH 10X16X17	2	
47	366217350	COVER, CLEANER (LOWER)	1	
48	366345980	KNOB, CLEANER COVER	2	
49	050200060	O-RING P6	2	
50	009110040	FLANGE BOLT 8X20	4	
51	959407670	SQUARE NUT M8	4	
53	366118890	GUARD, LINK	1	
54	366118900	GUARD, MUFFLER	1	
55	022910260	WELL NUT, M8	2	
56	366460170	FLANGE COLLAR 8	2	
57-1	001520820	SOCKET HEAD BOLT 8X20 T	4	
57-2	031108160	WASHER, FLAT M8	4	
58	009110038	SOCKET HEAD BOLT 8X30 ZN	2	
59	366217360	EX BAR	1	
60	009110039	SOCKET HEAD BOLT 6X25 ZN	4	
61	022910250	WELL NUT M6	4	
62	366118910	GUARD, ENGINE	1	
63	009110038	SOCKET HEAD BOLT 8X30 ZN	4	
65	366900032	COMBINATION LEVER ASSY W/ WIRE	1	INCLUDES ITEMS W/@
69@	956100062	THROTTLE WIRE	1	
70-1	001220620	BOLT 6X20 T	2	
70-2	030206150	WASHER, LOCK M6	2	
70-3	031106100	WASHER, FLAT M6	2	
71	020306050	NUT M6	2	
72	959006120	CLIP (TCP2-10509B)	1	
73	366460110	WIRE HARNESS	1	
74	2067550101	CLAMP	2	
75	959021810	SPIRAL TUBE KEP6/L=500	1	
76	454010020	CLAMP, TC-100	3	
101	366345190	CRANK GEAR	1	
106	366010110	FRONT COVER	1	S/N S-1392 AND BELOW
106	366010111	FRONT COVER	1	S/N S-1393 AND ABOVE
111	912210012	ENGINE, GX100UKRBF	1	

MTX70 — GUIDE CYLINDER AND SPRING ASSY.

GUIDE CYLINDER AND FOOT ASSY.

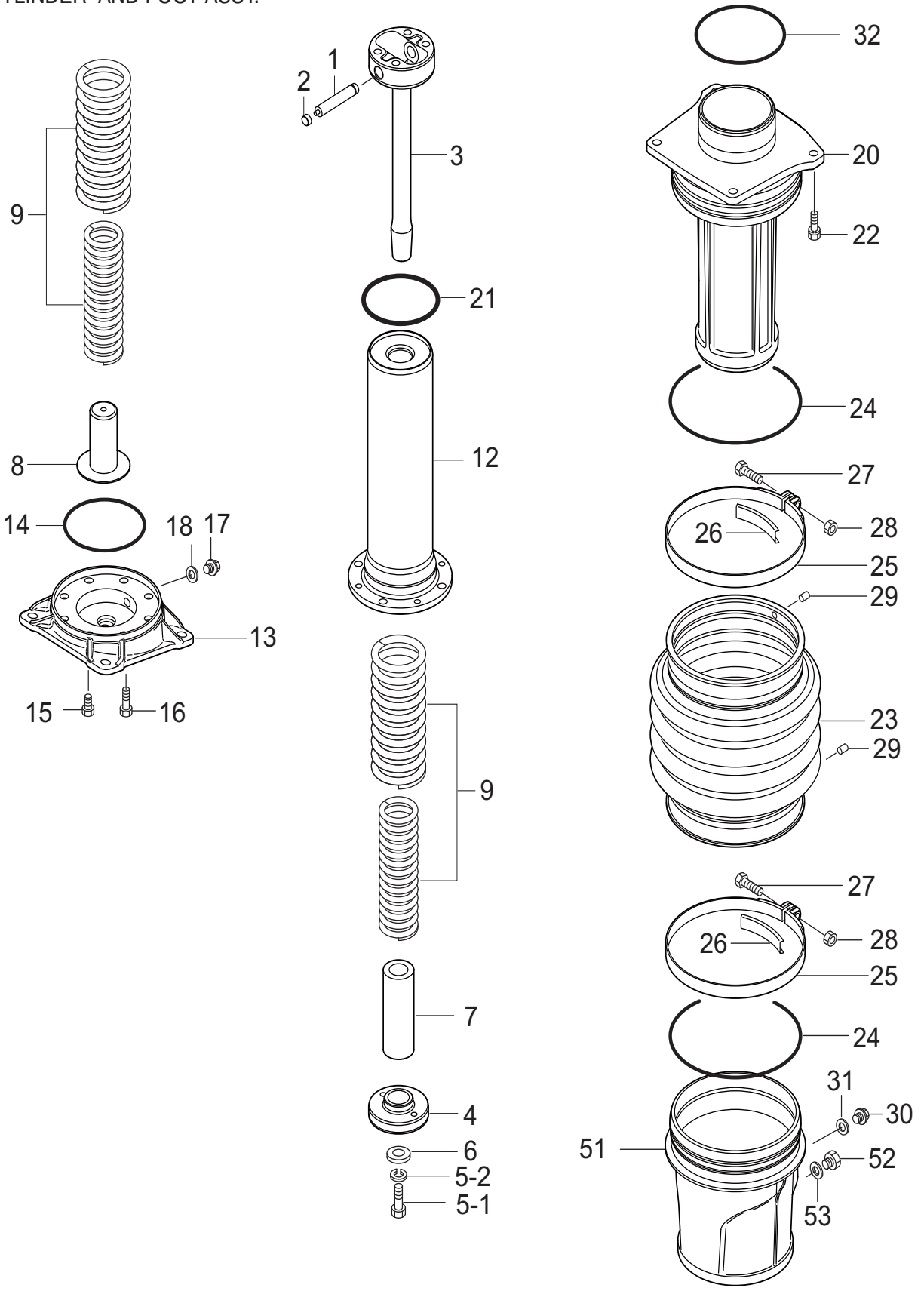

MTX70 — GUIDE CYLINDER AND SPRING ASSY.

GUIDE CYLINDER AND FOOT ASSY.

<u>NO.</u>	<u>PART NO.</u>	<u>PART NAME</u>	<u>QTY.</u>	<u>REMARKS</u>
1	366460100	PISTON PIN	1	
2	366459910	PLUG, PISTON PIN0	2	
3	366346000	PISTON ROD	1	
4	371459690	PISTON END	1	
5-1	001221230	BOLT 12X30 T	1	
5-2	030212300	WASHER, LOCK M12	1	
6	952404790	WASHER 13306	1	
7	355447260	STOPPER, LOWER	1	
8	366459900	STOPPER, BOTTOM	1	
9	366459730	MAIN SPRING	2	
12	366345990	SPRING CYLINDER	1	
13	366217210	FOOT PLATE 12	1	
14	050100900	O-RING G-90	1	
15	001521020	SOCKET HEAD BOLT 10X20 T	4	
16	001521040	SOCKET HEAD BOLT 10X40 T	4	
17	953405270	PLUG 1/4X14 13L	1	
18	953405260	PACKING 1/4 (CU)	1	
20	366217440	GUIDE CYLINDER	1	
21	050710070	O-RING AS568-344	1	
22	002211035	BOLT 10X35 H,SW	4	
23	354010010	BELLOWS, ORANGE	1	
24	050931500	O-RING JASO3150	2	
25	354336352	BELLOWS CLAMP(1.6T)171D	2	
26	354442340	BAND GUIDE, BELLOWS	2	
27	001220840	BOLT 8X40 T	2	
28	020308060	NUT M8	2	
29	354446170	PIN 6D-8.5L	2	
30	953405270	PLUG 1/4X14 13L	1	
31	953405260	PACKING 1/4 (CU)	1	
32	050200950	O-RING P-95	1	
51	366118590	PROTECTION SLEEVE	1	
52	366460300	OIL GAUGE ASSY	1	
53	953404670	COPPER PACKING 17X25.5X1	1	

FOOT ASSY.

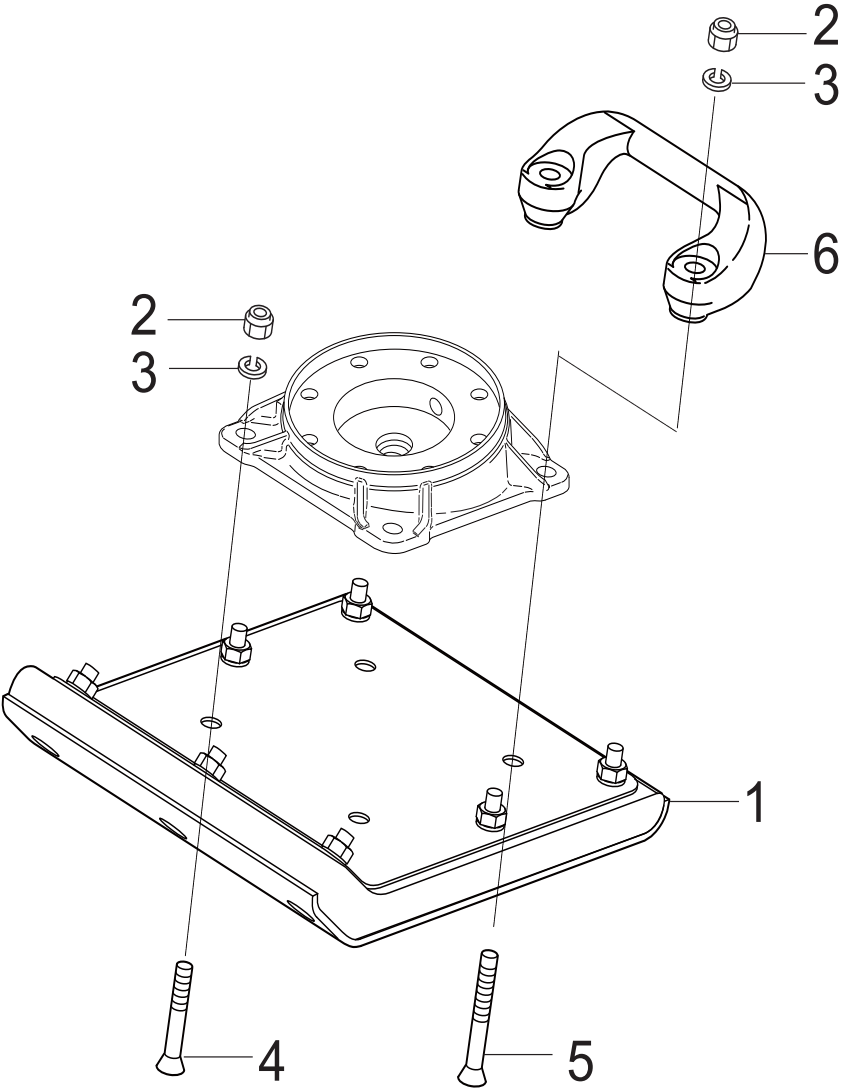

FOOT ASSY.

<u>NO.</u>	<u>PART NO.</u>	<u>PART NAME</u>	<u>QTY.</u>	<u>REMARKS</u>
1	366910020	FOOT ASSY 285	1	
2	022711214	NYLON NUT M12	4	
3	030212300	WASHER, LOCK M12	4	
4	009110034	BOLT, SQUARE NECK 12X65	2	
5	009110035	BOLT, SQUARE NECK 12X95	2	
6	363343390	GRIP HANDLEBAR	1	

MTX70 — TANK AND HANDLE ASSY.

TANK AND HANDLE ASSY.

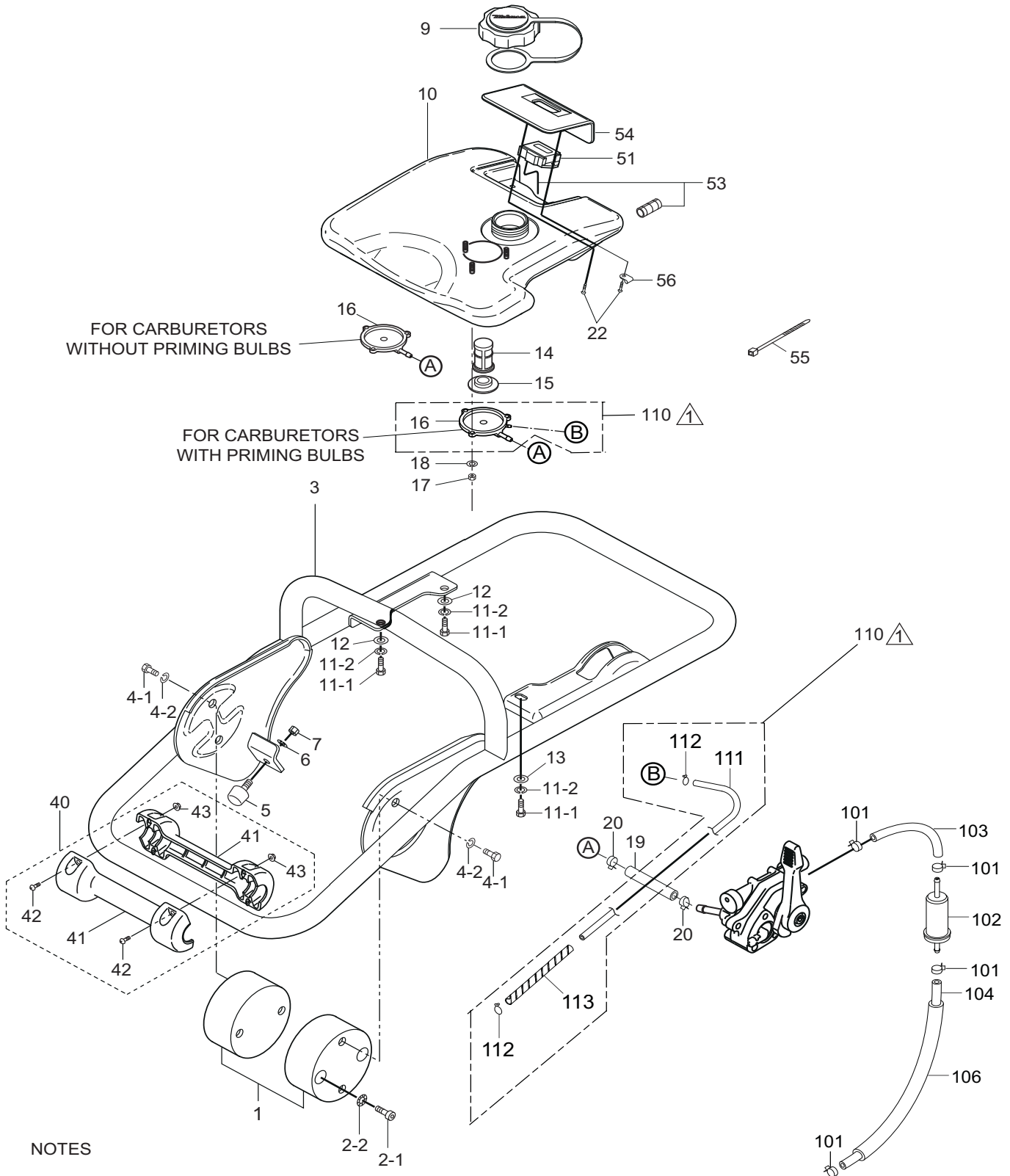

NOTES

- ⚠ ITEM 110, PRIMER PUMP KIT, FOR USE ON UNITS WITH S/N T-3363 AND ABOVE

MTX70 — TANK AND HANDLE ASSY.

TANK AND HANDLE ASSY.

<u>NO.</u>	<u>PART NO.</u>	<u>PART NAME</u>	<u>QTY.</u>	<u>REMARKS</u>
1	366346270	SHOCK ABSORBER W/PIN	2	
2-1	001521020	SOCKET HEAD BOLT 10 X 20 T	4	
2-2	033121009	TOOTHED LOCK WASHER B M10	4	
3	366119040	HANDLE / MTX70	1	
4-1	001211020	BOLT 10 X 20 H	4	
4-2	030210250	WASHER, LOCK M10	4	
5	939010270	STOPPER RUBBER (70)	1	
6	030208200	WASHER, LOCK M8	1	
7	020308060	NUT M8	1	
9	366900020	CAP ASSY, FUEL TANK	1	
10	366118700	FUEL TANK / MTX70	1	
11-1	001210815	BOLT 8X15 H	3	
11-2	030208200	WASHER, LOCK M8	3	
12	952401450	WASHER 8.5 X 22 X 3	2	
13	031108160	WASHER, FLAT M8	1	
14	954406010	STRAINER #110	1	
15	366459790	PACKING, FUEL TANK	1	
16	366345280	HOLDER, FILTER	1	S/N T-3362 AND BELOW
16%	366349420	HOLDER, FILTER W/V	1	S/N T-3363 AND ABOVE
17	020305040	NUT M5	3	
18	030205130	WASHER, LOCK M5	3	
19	959026122	FUEL HOSE L=70	1	
20	954406420	HOSE BAND 10.5	2	
22	009110037	TAPPING SCREW 5 X 20	2	
40	366910030	ROLLER ASSY W/SCREW	1	INCLUDES ITEMS W/#
41#	366217170	ROLLER	2	
42#	091005020	SCREW 5 X 20	4	
43#	022610505	FLANGE NUT M5 H	4	
51	955010311	TP22 TACHO/HOUR METER	1	
53	955010305	CURL CORD TP22	1	
54	366345620	FINISHER, METER	1	
55	454010020	CLAMP TC100	5	
56	954010270	CLIP AB-3N	1	
101	954406420	HOSE BAND 10.5	4	
102	16910Z4ES21	STRAINER, FUEL	1	
103	959026103	FUEL HOSE 5.5 X 11.5 X 80	1	
104	950014500150M	FUEL HOSE (1M)	1	
106	950033606020	TUBE, VINYL L260	1	
110	366900060	PRIMER PUMP KIT / NO CARB	1	INCLUDES ITEMS W/% S/N T-3363 AND ABOVE
111%	959028301	RETURN HOSE 3 X 6 X 600	1	S/N T-3363 AND ABOVE
112%	954408170	HOSE CLIP	5	S/N T-3363 AND ABOVE
113%	959021814	SPIRAL TUBE 6D-200L	1	S/N T-3363 AND ABOVE

MTX70 — COMBINATION LEVER ASSY.

COMBINATION LEVER ASSY.

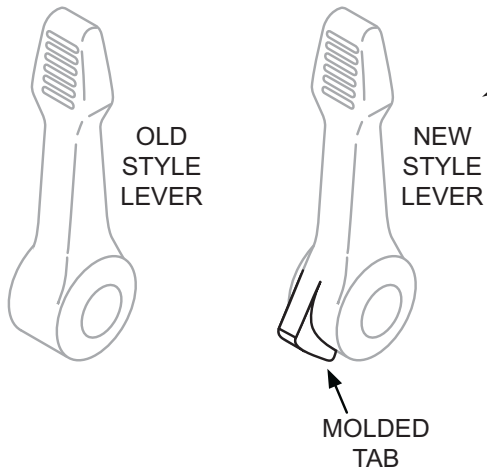
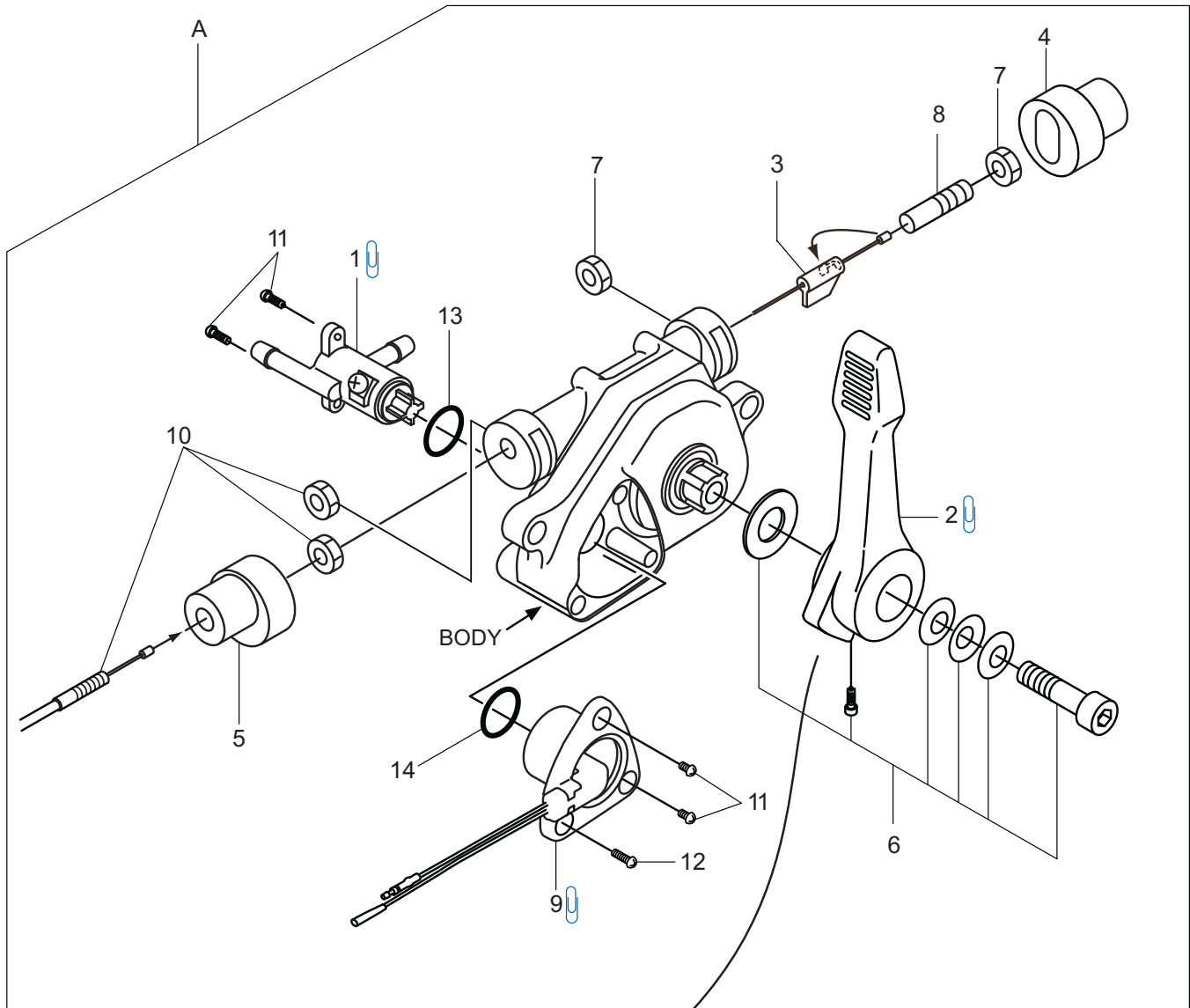

NOTES



OLD STYLE LEVER BODY NO LONGER AVAILABLE. NEW STYLE ITEMS 1, 2, AND 9 ARE NOT COMPATIBLE WITH OLD STYLE BODY. IF REPLACEMENT OF ITEMS 1, 2 OR 9 IS REQUIRED, ORDER KIT "A".

TO DETERMINE IF COMBINATION LEVER ASSY IS OLD STYLE OR NEW STYLE, SEE ITEM 2, LEVER. NEW STYLE LEVER HAS MOLDED TAB AT BOTTOM.

MTX70 — COMBINATION LEVER ASSY.

COMBINATION LEVER ASSY.

<u>NO.</u>	<u>PART NO.</u>	<u>PART NAME</u>	<u>QTY.</u>	<u>REMARKS</u>
A	366900032	COMB. LEVER ASSY W/ THROTTLE WIRE	1	INCLUDES ITEMS W/ # REPLACES 366900030
A	956200110	COMB. LEVER	1	INCLUDES ITEMS W/@
1	366346260	FUEL COCK	1	SEE NOTE ON DRAWING
1#@	366349430	FUEL COCK	1	NEW STYLE, SEE NOTE ON DRAWING
2	366010180	LEVER	1	SEE NOTE ON DRAWING
2#@	366010310	LEVER	1	NEW STYLE, SEE NOTE ON DRAWING
3#@	366010190	SLIDER	1	
4#@	366010200	END CAP	1	
5#@	366010210	WIRE CAP	1	
6#@	366010220	BOLT AND WASHER SET	1	
7#@	020408050	NUT M8, H=5	2	
8#@	959407650	SOCKET HEAD SCREW/TH.WIRE	1	
9	366010260	STOP SWITCH	1	SEE NOTE ON DRAWING
9#@	366010320	STOP SWITCH	1	NEW STYLE, SEE NOTE ON DRAWING
10#	956100062	THROTTLE WIRE	1	
11#@	094010051	TAPPING SCREW B1 4X12	4	
12#@	094010052	TAPPING SCREW B1 4X30	1	
13#@	050200150	O-RING, P15	1	
14#@	050200110	O-RING, P11	1	

TOOLS

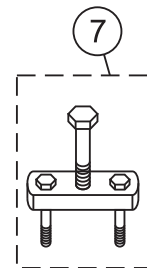
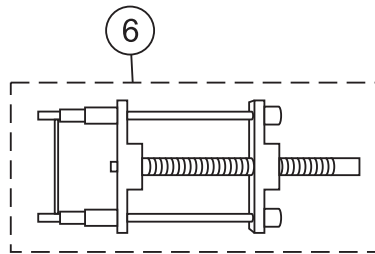
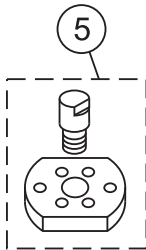
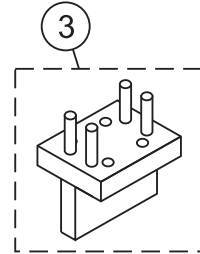
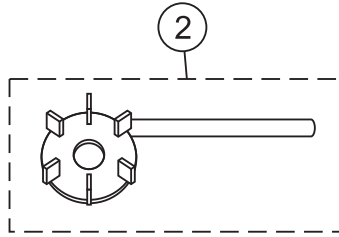
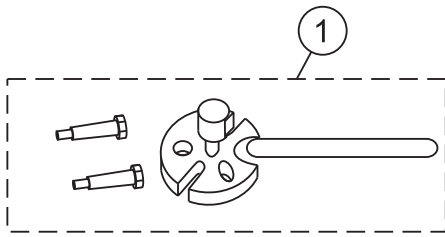

TOOLS

<u>NO.</u>	<u>PART NO.</u>	<u>PART NAME</u>	<u>QTY.</u>	<u>REMARKS</u>
1	981010400	CLUTCH PULLER A	1	
2	983010060	CLUTCH MOUNTER	1	
3	983910090	PISTON ROD HOLDER	1	
4	009110044	SOCKET HEAD BOLT 8X50 (FULL THREAD)		
		CRANK GEAR REMOVER	2	
5	983910020	CLUTCH PULLER B	1	
6	983010040	SPRING CYLINDER REMOVER	1	
7	983910010	PISTON END REMOVER	1	

HONDA GX100UKRBF ENGINE — CYLINDER BARREL ASSY.

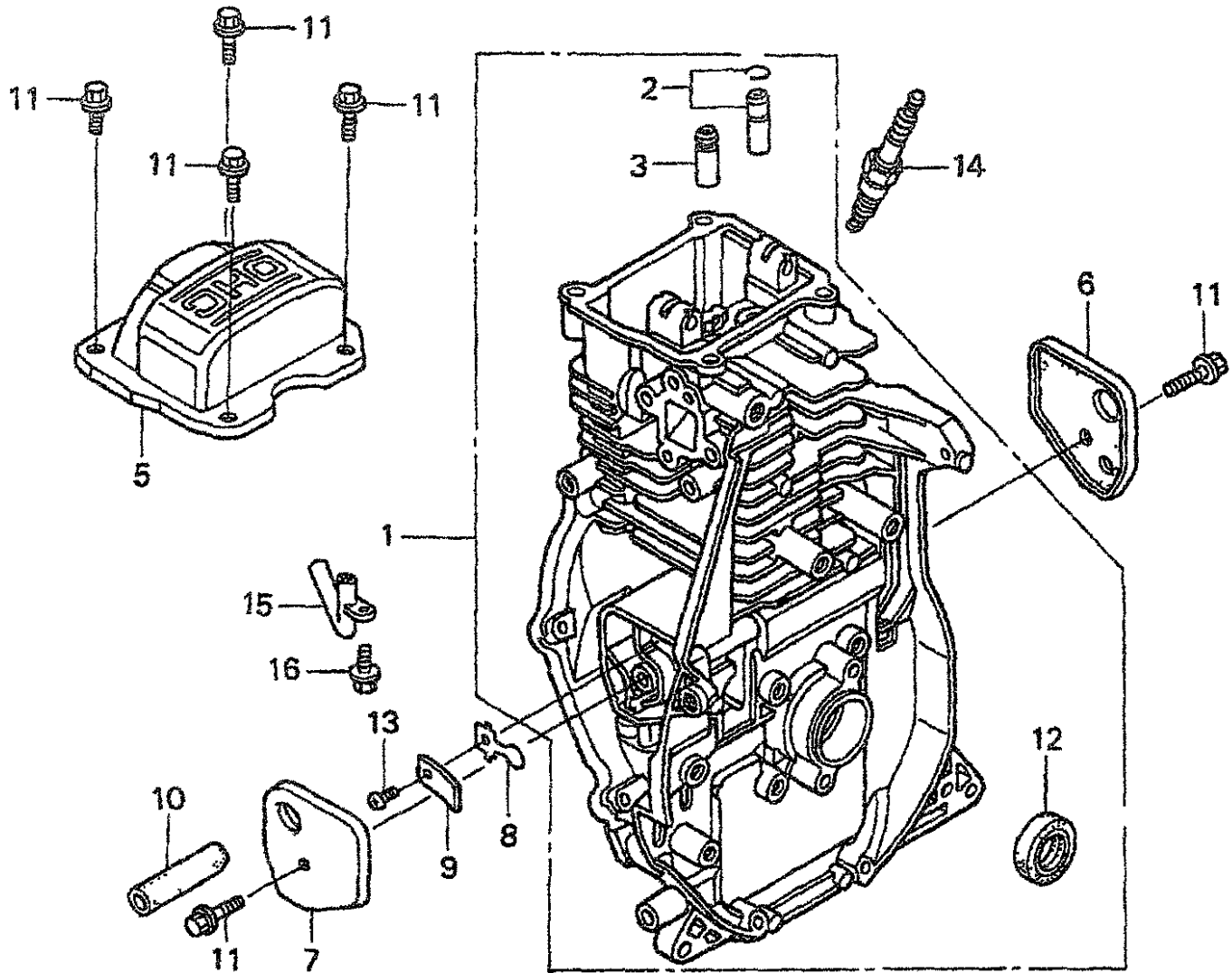

HONDA GX100UKRBF ENGINE — CYLINDER BARREL ASSY.

CYLINDER BARREL ASSY.

<u>NO.</u>	<u>PART NO.</u>	<u>PART NAME</u>	<u>QTY.</u>	<u>REMARKS</u>
1	12000Z0DV00	BARREL ASSY., CYLINDER	1.....	INCLUDES ITEMS W/@
2@	12201Z0D305	GUIDE ASSY., EX VALVE (O.S.)	1	
3@	12204Z0D305	GUIDE, INLET VALVE (O.S)	1	
5	12311Z0D000	COVER, HEAD T	1	
6	12355Z0D000	COVER COMP A, BREATHER	1	
7	12365Z0D000	COVER COMP B, BREATHER	1	
8	15571Z0DV71	VALVE, OIL OUTLET	1	
9	15572ZM7000	PLATE, STOPPER	1	
10	15721Z0DV70	TUBE, BREATHER	1	
11	90014952000	VOLT, FLANGE 6X14 (CT200)	6	
12@	91202KJ9003	OIL SEAL 20X32X6	1	
13	93500030050A	SCREW 3X5	1	
14	9805655757	PLUG, SPARK (U16FSR-UB)	1	
15	15171Z0DV00	PIPE, BREATHER	1	
16	90008ZM7000	BOLT 4X10	1	

HONDA GX100UKRBF ENGINE — CRANKCASE COVER ASSY.

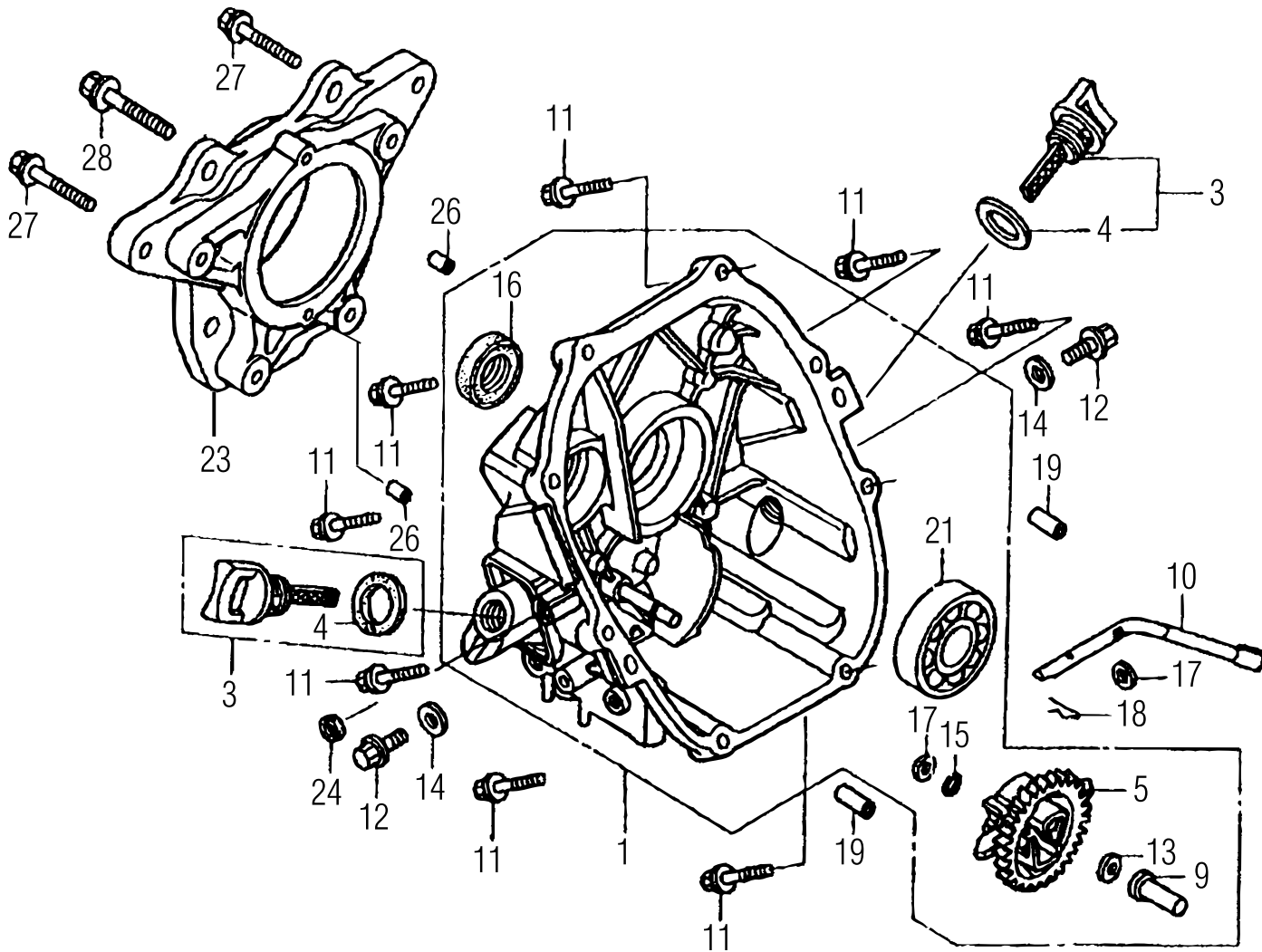

HONDA GX100UKRBF ENGINE — CRANKCASE COVER ASSY.

CRANKCASE COVER ASSY.

NO.	PART NO.	PART NAME	QTY.	REMARKS
1	11300Z0D409	COVER ASSY., CRANK CASE	1.....	INCLUDES ITEMS W/@
3	15600ZM7003	OIL FILLER CAP ASSY	2.....	INCLUDES ITEMS W/#
4#	15625ZE1003	PACKING, OIL FILLER CAP	2	
5@	16510ZL8000	GOVERNOR ASSY.	1	
9@	16531ZE1000	SLIDER, GOVERNOR	1	
10	16541Z0D000	SHAFT, GOVERNOR ARM	1	
11	90121952000	FLANGE BOLT 6x25	8	
12	90131ZE1000	BOLT, DRAIN PLUG	1	
13@	90451ZE1000	THRUST WASHER 6 MM	1	
14	90601ZE1000	WASHER, DRAIN PLUG	1	
15@	90602ZE1000	CLIP, GOVERNOR HOLDER	1	
16@	91202KJ9003	OIL SEAL 20x3x6	1	
17@	9410106800	PLAIN WASHER 6 MM	2	
18	9425108000	LOCK PIN	1	
19	9430108200	KNOCK PIN	2	
21@	91001Z0DV01	BEARING, RADIAL BALL 6204	1	
23	11511Z0DV10	FLANGE JOINT PTO	1	
24	91231891003	OIL SEAL 6x11x4	1	
26	9430306100	KNOCK PIN 6x10	2	
27	957010804500	FLANGE BOLT 8x40	4	
28	934021004000	BOLT WASHER 10x40	2	

HONDA GX100UKRBF ENGINE — CRANKSHAFT ASSY.

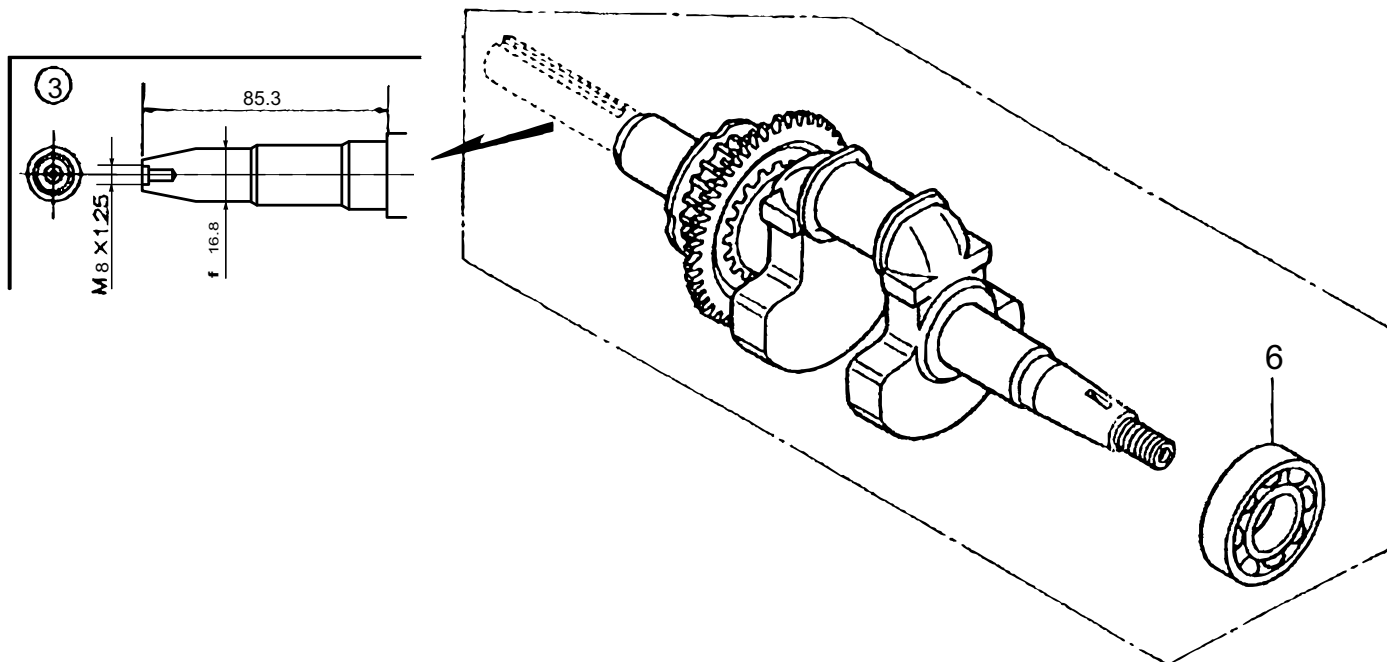

HONDA GX100UKRBF ENGINE — CRANKSHAFT ASSY.

CRANKSHAFT ASSY.

<u>NO.</u>	<u>PART NO.</u>	<u>PART NAME</u>	<u>QTY.</u>	<u>REMARKS</u>
3	13310Z0DV70	CRANK SHAFT COMP.....	1.....	INCLUDES ITEM W/ @
6@	91001Z0DV01	BEARING, RADIAL BALL	2	

HONDA GX100UKRBF ENGINE — PISTON CONNECTING ROD ASSY.

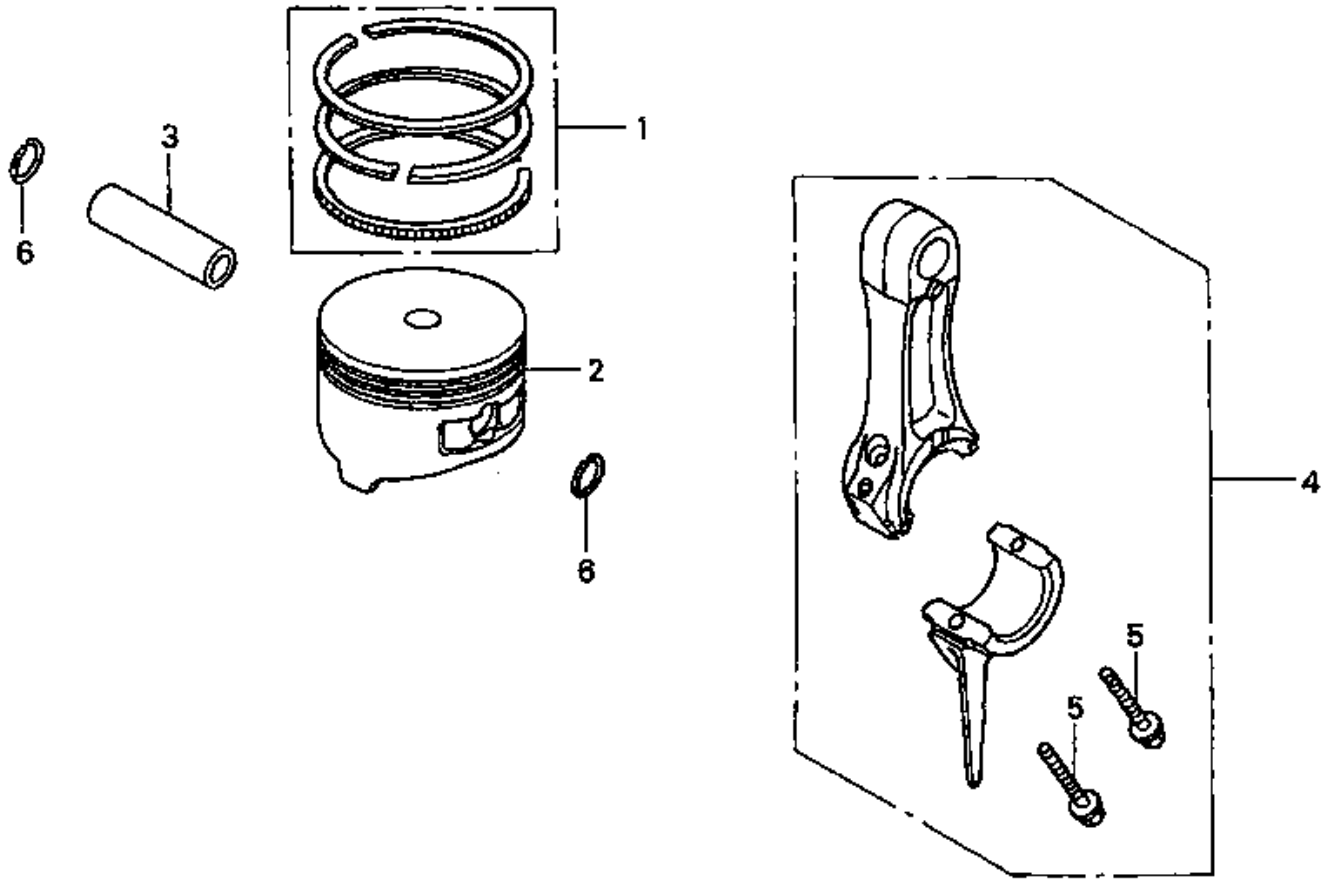

HONDA GX100UKRBF ENGINE — PISTON CONNECTING ROD ASSY.

PISTON CONNECTING ROD ASSY.

<u>NO.</u>	<u>PART NO.</u>	<u>PART NAME</u>	<u>QTY.</u>	<u>REMARKS</u>
1	13010Z0D003	RING SET, PISTON	1	
2	13101Z0D000	PISTON	1	
3	13111ZE0000	PISTON PIN	1	
4	13200Z0D000	CONNECTING ROD ASSY.	1	INCLUDES ITEM W/ @
4	13200Z0D305	CONNECTING ROD ASSY.	1	UNDERSIZE, INCLUDES ITEM W/ @
5@	90001ZM7000	CONNECTING ROD BOLT	2	
6	90551ZE0000	CLIP, PISTON PIN 13MM	2	

HONDA GX100UKRBF ENGINE — CAMSHAFT ASSY.

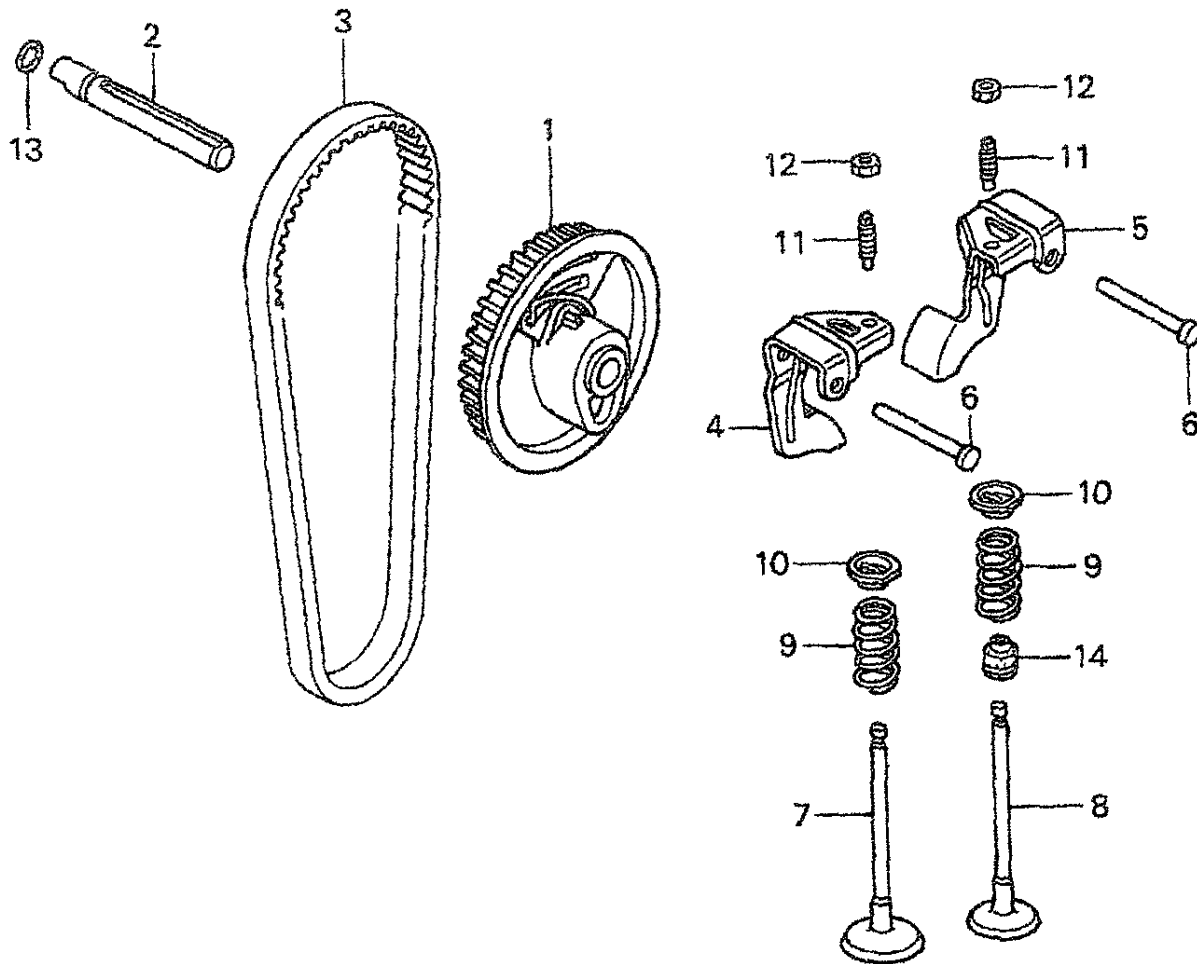

HONDA GX100UKRBF ENGINE —CAMSHAFT ASSY.

CAMSHAFT ASSY.

<u>NO.</u>	<u>PART NO.</u>	<u>PART NAME</u>	<u>QTY.</u>	<u>REMARKS</u>
1	14320Z0D010	PULLEY, COMP., CAMSHAFT	1	
2	14324Z0D000	SHAFT, CAM PULLEY	1	
3	14400Z0D003	TIMING BELT (61YU7 G-200)	1	
4	14431Z0D000	ROCKER ARM, INTAKE VALVE	1	
5	14441Z0D000	ROCKER ARM, EXHAUST VALVE	1	
6	14461ZL8000	SHAFT, ROCKER ARM	2	
7	14711Z0D000	INLET VALVE	1	
8	14721Z0D000	EXHAUST VALVE	1	
9	14751Z0D000	SPRING, VALVE	2	
10	14771ZM3010	RETAINER, VALVE SPRING	2	
11	90012333000	SCREW, TAPPET ADJUSTING	2	
12	90206001000	NUT, TAPPET ADJUSTING	2	
13	91301ZM0V31	O RING 6.8X1.9	1	
14	12209KT7013	SEAL, VALVE STEM	1	

HONDA GX100UKRBF ENGINE — RECOIL STARTER ASSY.

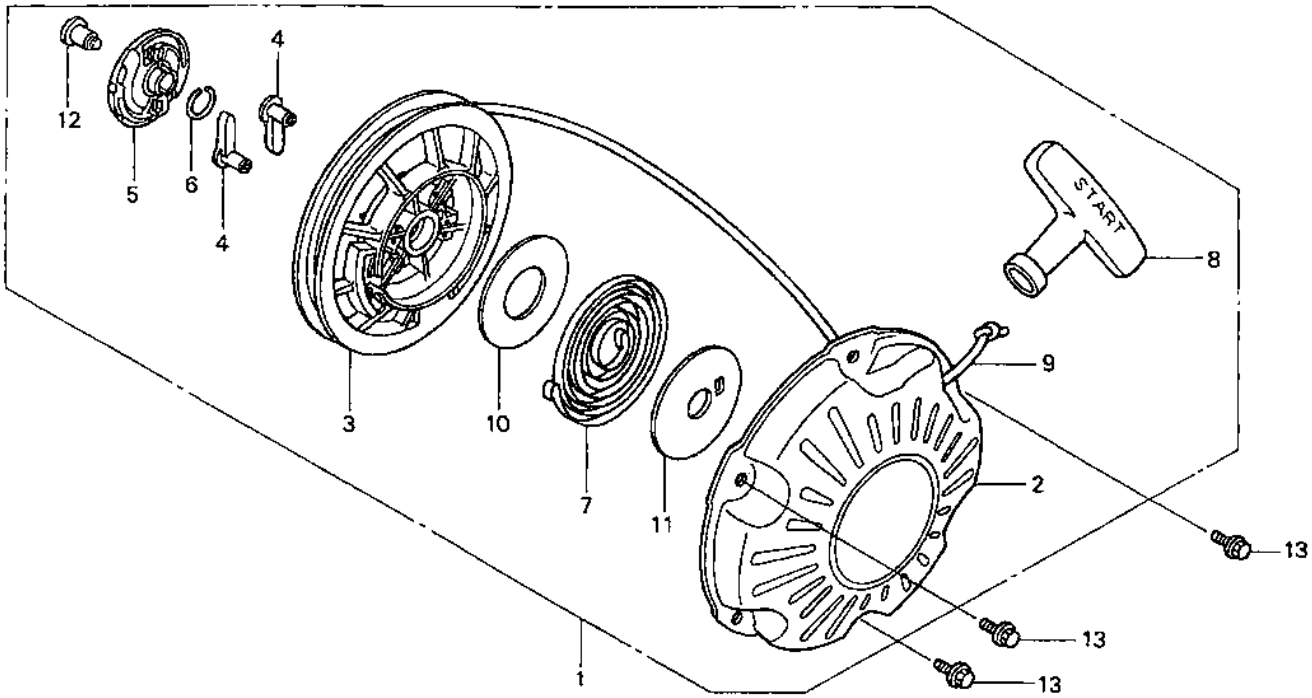

HONDA GX100UKRBF ENGINE — RECOIL STARTER ASSY.

RECOIL STARTER ASSY.

<u>NO.</u>	<u>PART NO.</u>	<u>PART NAME</u>	<u>QTY.</u>	<u>REMARKS</u>
1	28400Z0DV03ZA	RECOIL STARTER ASSY.....	1.....	INCLUDES ITEMS W/ @
2@	28410Z0DV02ZA	CASE COMP., RECOIL @5-3-5	1	
3@	28421Z0DV02	REEL, RECOIL STARTER	1	
4@	28422ZG0W02	RATCHET, STARTER	1	
5@	28433ZG0W02	GUIDE, RATCHET	1	
6@	28441ZW6003	SPRING, FRICTION	1	
7@	28442ZH8003	SPRING, RECOIL STARTER	1	
8@	28461ZH8003	STARTER KNOB	1	
9@	28462Z0DV02	ROPE, RECOIL STARTER	1	
10@	28467Z0DV02	PLATE, SIDE	1	
11@	28468Z0DV02	PLATE, SLIDE	1	
12@	90003ZH8003	SET SCREW	1	
13	957010600800	BOLT, FLANGE 6X8	1	

HONDA GX100UKRBF ENGINE — FAN COVER ASSY.

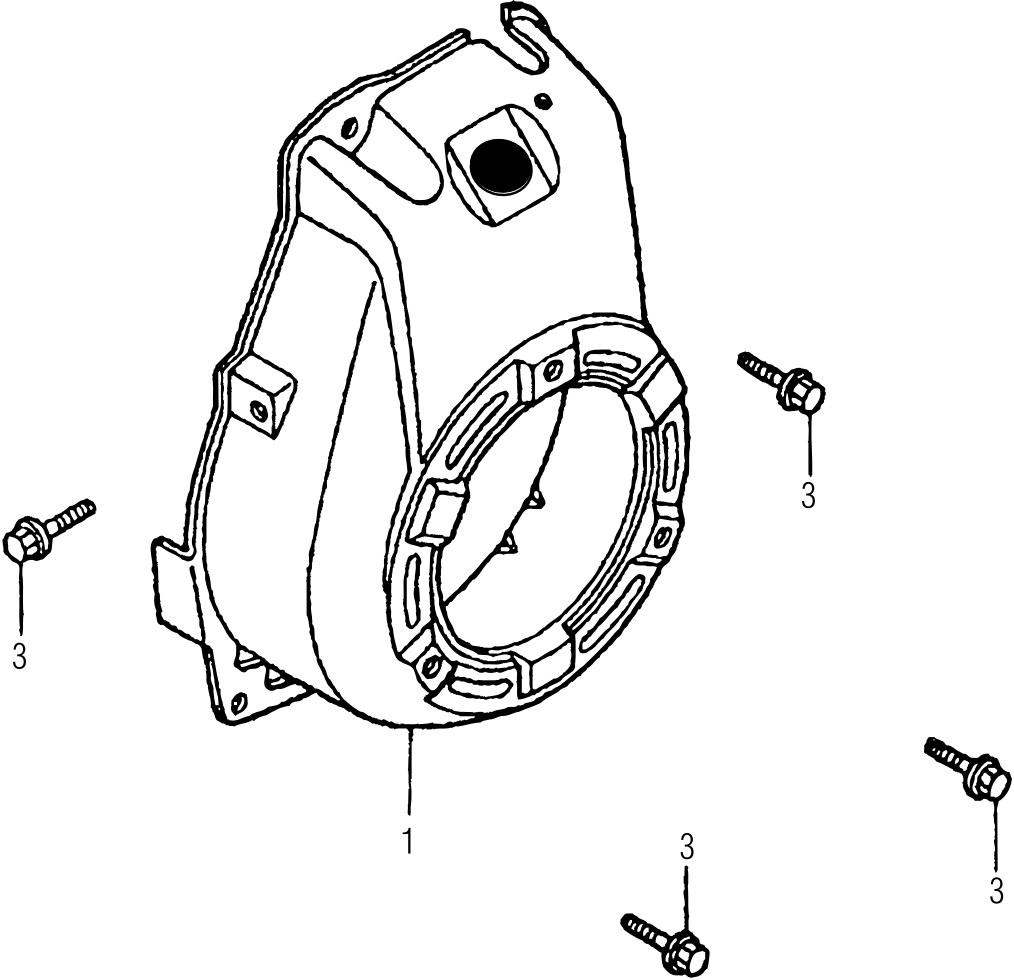

HONDA GX100UKRBF ENGINE — FAN COVER ASSY.

FAN COVER ASSY.

<u>NO.</u>	<u>PART NO.</u>	<u>PART NAME</u>	<u>QTY.</u>	<u>REMARKS</u>
1	19610Z0DV00ZB	FAN COVER CP.	1	
3	90014952000	BOLT, FLANGE 6X14 (CT200)	4	

HONDA GX100UKRBF ENGINE — CARBURETOR ASSY. (S/NT-3362 AND BELOW)

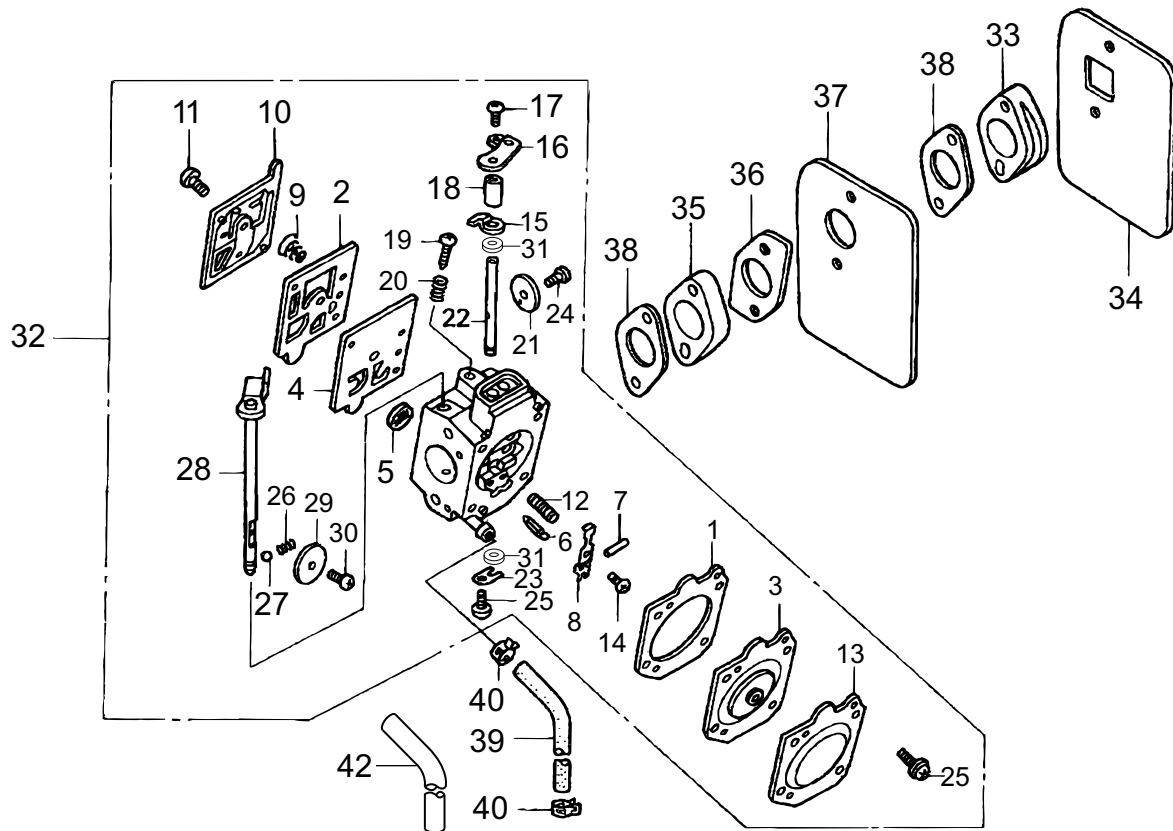

HONDA GX100UKRBF ENGINE — CARBURETOR ASSY. (S/N T-3362 AND BELOW)

CARBURETOR ASSY. (S/N T-3362 AND BELOW)

<u>NO.</u>	<u>PART NO.</u>	<u>PART NAME</u>	<u>QTY.</u>	<u>REMARKS</u>
1@	16010Z0DV02	GASKET, METALING DIAPHRAGM	1	
2@	16011Z0DV02	GASKET, PUMP	1	
3@	16013Z0DV02	DIAPHRAGM ASSY, METALING	1	
4@	16014Z0DV02	DIAPHRAGM, PUMP	1	
5@	16018ZM3004	SCREEN, INLET	1	
6@	16019ZM3004	VALVE, INLET NEEDLE	1	
7@	16022ZM3014	PIN, METALING LEVER	1	
8@	16023Z0DV02	LEVER, METALING	1	
9@	16030ZM3004	SPRING, PUMP	1	
10@	16040Z0DV02	COVER, PUMP	1	
11@	16041Z0DV02	SCREW	1	
12@	16042Z0EV92	SPRING	1	
13@	16043Z0DV02	COVER, METALING DIAPHRAGM	1	
14@	16044Z0DV02	SCREW	1	
15@	16045Z0DV02	STOPPER, THROTTLE LEVER	1	
16@	16046Z0DV73	LEVER, THROTTLE	1	
17@	16054Z0DV02	SCREW, VALVE	1	
18@	16048Z0DV02	SPACER, THROTTLE LEVER	1	
19@	16049Z4ES12	SCREW, IDLE ADJUSTING	1	
20@	16050Z0DV02	SPRING	1	
21@	16051Z0DV02	VALVE, THROTTLE	1	
22@	16052Z0DV02	SHAFT, THROTTLE	1	
23@	16053Z0DV02	CLIP, THROTTLE SHAFT	1	
24@	16054Z0DV02	SCREW, VALVE	1	
25@	16055Z0DV02	SCREW ASSY	5	
26@	16056Z0DV02	SPRING	1	
27@	16057Z0DV02	BALL	1	
28@	16058Z0DV72	SHAFT ASSY, CHOKE	1	
29@	16059Z0DV03	VALVE, CHOKE	1	
30@	16060Z0DV02	SCREW	1	
31@	16061Z0DV02	SEAL, DUST	2	
32	16100Z4ES13	CARBURETOR ASSY. (HAD 201C).....	1.....	INCLUDES ITEMS W/ @
33	16211Z0DV00	INSULATOR, CARBURETOR	1	
34	16212Z0DV00	PACKING, INSULATOR	1	
35	16213Z4ES10	INSULATOR B, CARBURETOR	1	
36	16214Z0DV00	PACKING B, INSULATOR	1	
37	16215Z0DV00	PLATE, INSULATOR	1	
38	16221Z0DV00	PACKING, CARBURETOR	2	
39	950014527050	HOSE, FUEL 4.5 X 270	1	
40	950024085008	CLAMP, TUBE	2	
42	16552896650	COLLAR, LEVER	1	

HONDA GX100UKRBF ENGINE — CARBURETOR ASSY. (S/NT-3363 AND ABOVE)

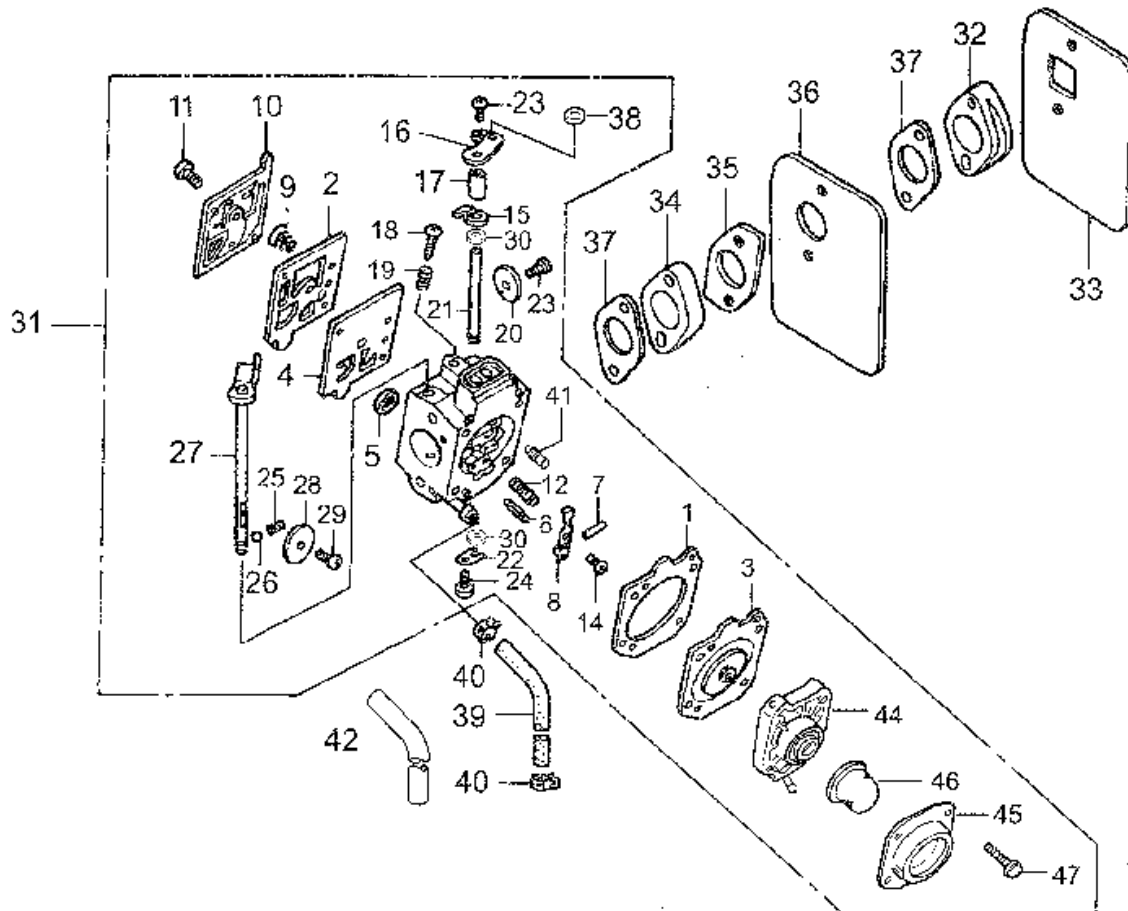

HONDA GX100UKRBF ENGINE — CARBURETOR ASSY. (S/N T-3363 AND ABOVE)

CARBURETOR ASSY. (S/N T-3363 AND ABOVE)

<u>NO.</u>	<u>PART NO.</u>	<u>PART NAME</u>	<u>QTY.</u>	<u>REMARKS</u>
1@	16010Z0DV02	GASKET, METERING DIAPHRAGM	1	
2@	16011Z0DV02	GASKET, PUMP	1	
3@	16013Z4ES32	DIAPHRAGM ASSY, METERING	1	
4@	16014Z0DV02	DIAPHRAGM, PUMP	1	
5@	16018ZM3004	SCREEN, INLET	1	
6@	16019ZM3004	VALVE, INLET NEEDLE	1	
7@	16022ZM3014	PIN, METERING LEVER	1	
8@	16023Z0DV02	LEVER, METERING	1	
9@	16030ZM3004	SPRING, PUMP	1	
10@	16040Z4E802	COVER, PUMP	1	
11@	16041Z0DV02	SCREW	1	
12@	16042Z0DV02	SPRING	1	
14@	16044Z4E802	SCREW	1	
15@	16045Z0DV02	STOP, THROTTLE	1	
16@	16046Z0DV73	LEVER, THROTTLE	1	
17@	16048Z0DV02	SPACER, THROTTLE LEVER	1	
18@	16049Z4ES12	SCREW, IDLE ADJUSTING	1	
19@	16050Z0DV02	SPRING	1	
20@	16051Z0DV02	VALVE, THROTTLE	1	
21@	16052Z0DV02	SHAFT, THROTTLE	1	
22@	16053Z0DV02	CLIP, THROTTLE SHAFT	1	
23@	16054Z0DV02	SCREW, VALVE	2	
24@	16055Z0DV02	SCREW ASSY	1	
25@	16056Z0DV02	SPRING	1	
26@	16057Z0DV02	BALL	1	
27@	16058Z0DV02	SHAFT ASSY, CHOKE	1	
28@	16059Z0DV03	VALVE, CHOKE	1	
29@	16060Z0DV02	SCREW	1	
30@	16061Z0DV02	SEAL, DUST	2	
31	16100Z4ES43	CARBURETOR ASSY (W/PRIMER).....	1.....	INCLUDES ITEMS W/@
32	16211Z0DV00	INSULATOR, CARBURETOR	1	
33	16212Z0DV00	PACKING, INSULATOR	1	
34	16213Z4ES10	INSULATOR B, CARBURETOR	1	
35	16214Z0DV00	PACKING B, INSULATOR	1	
36	16215Z0DV00	PLATE, INSULATOR	1	
37	16221Z0DV00	PACKING, CARBURETOR	2	
38@	16552896650	COLLAR, LEVER	1	
39	950014527050	HOSE, FUEL 4.5 X 270	1	
40	950024085008	CLAMP, TUBE	2	
41@	99101Z0D0480	JET (#48)	1.....	OVER 7000
41@	99101Z0D0500	JET (#50)	1.....	5000-7000
41@	99101Z0D0520	JET (#52)	1.....	STANDARD
42	950033602620	TUBE, VINYL. 11 X 13 X 260	1	
44@	16017Z4ES32	BODY ASSY, AIRPURGE	1	
45@	16026Z4ES32	COVER, PRIMER PUMP	1	
46@	16032Z4ES32	PUMP, PRIMER	1	
47@	16055Z4ES32	SCREW ASSY	4	

HONDA GX100UKRBF ENGINE — AIR CLEANER ASSY.

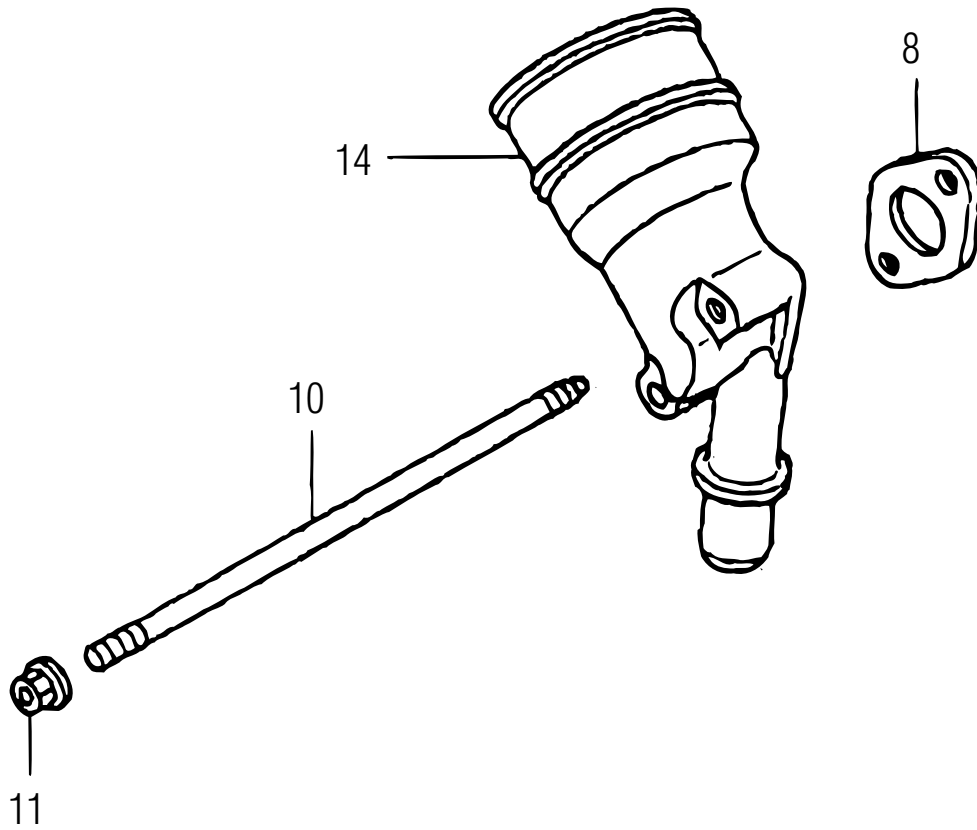

HONDA GX100UKRBF ENGINE — AIR CLEANER ASSY.

AIR CLEANER ASSY.

<u>NO.</u>	<u>PART NO.</u>	<u>PART NAME</u>	<u>QTY.</u>	<u>REMARKS</u>
8	17228Z0DV01	PACKING, AIR CLEANER	1	
10	90042Z4ES30	STUD BOLT 5X95	2	
11	9405005000	FLANGE NUT 5MM	2	
14	17410Z4ES30	ELBOW, AIR CLEANER	1	

HONDA GX100UKRBF ENGINE — MUFFLER ASSY.

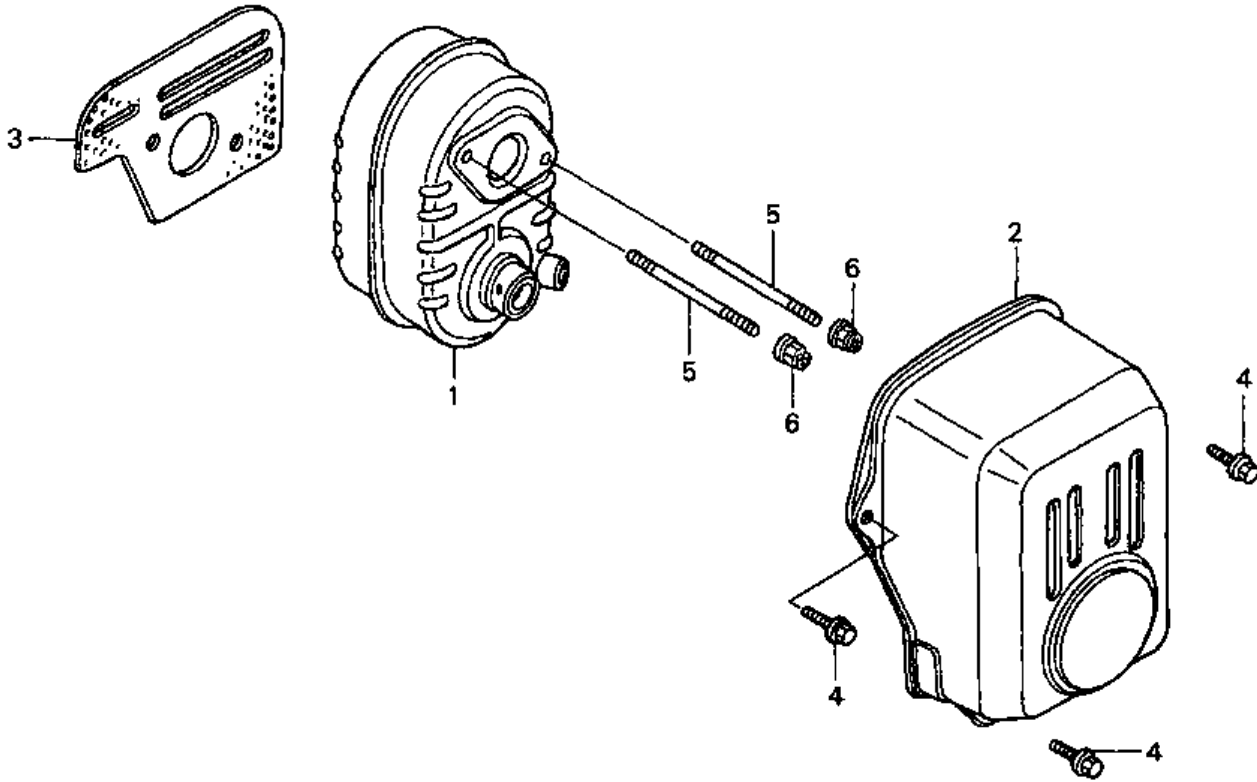

HONDA GX100UKRBF ENGINE — MUFFLER ASSY.

MUFFLER ASSY.

<u>NO.</u>	<u>PART NO.</u>	<u>PART NAME</u>	<u>QTY.</u>	<u>REMARKS</u>
1	18310Z0DV20	MUFFLER COMP.	1	
2	18321Z0DV20	MUFFLER PROTECTOR	1	
3	18381Z0D000	GASKET, MUFFLER	1	
4	90014952000	VOLT, FLANGE 6X14 (CT200)	3	
5	90048Z0DV00	STUD BOLT 5X78	2	
6	90343ZE6000	NUT, SELF-LOCK 6MM	2	

HONDA GX100UKRBF ENGINE — FLYWHEEL IGNITION ASSY.

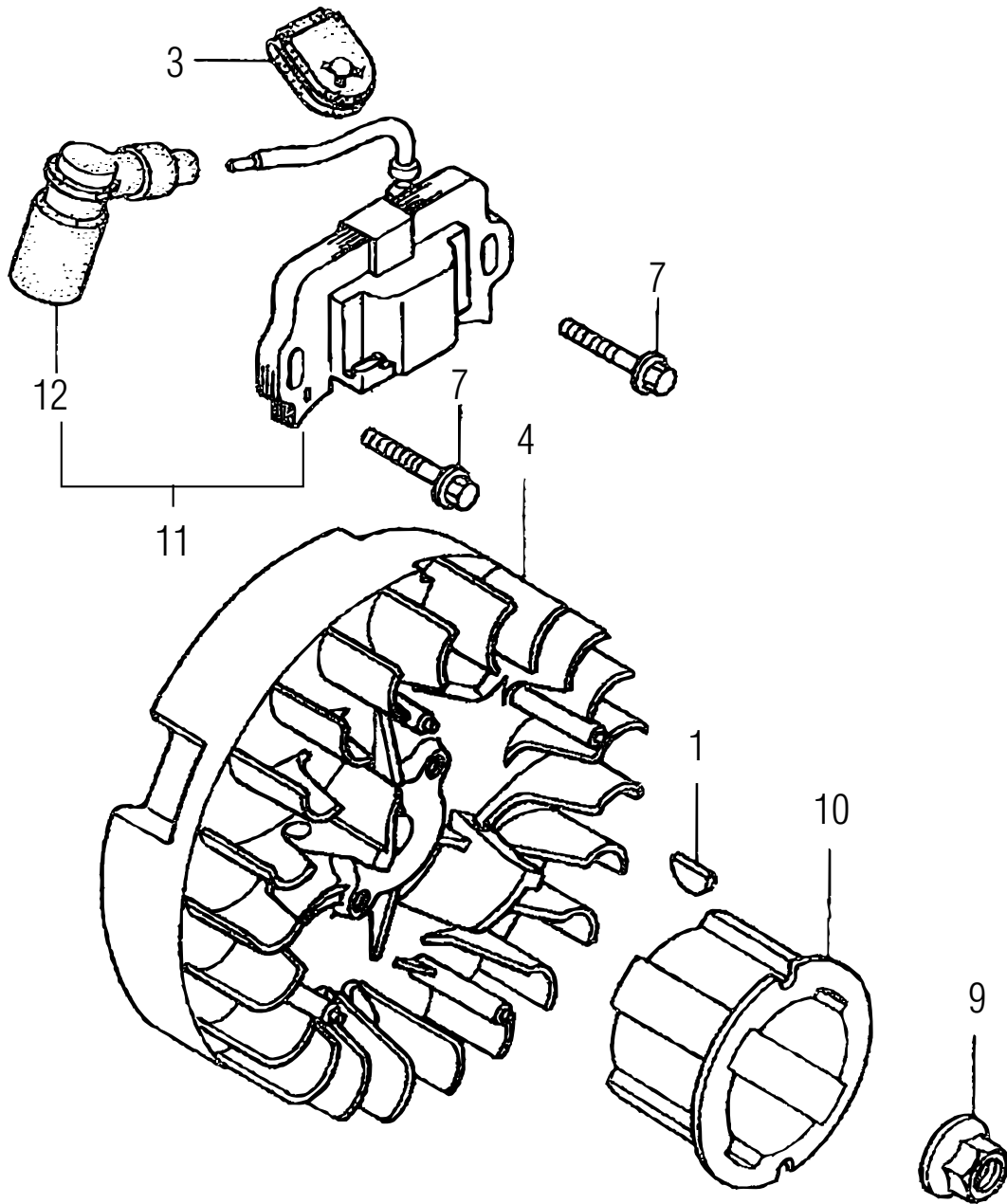

HONDA GX100UKRBF ENGINE — FLYWHEEL IGNITION ASSY.

FLYWHEEL IGNITION ASSY.

<u>NO.</u>	<u>PART NO.</u>	<u>PART NAME</u>	<u>QTY.</u>	<u>REMARKS</u>
1	13331ZM7000	WOODRUFF KEY 25X18	1	
3	30564ZA5000	GROMMET, CORD	1	
4	31110Z0D003	FLYWHEEL COMP.	1	
7	90022888010	FLANGE BOLT 6X20	2	
9	9405012000	FLANGE NUT M12	1	
10	28451Z0DV02	STARTER PULLEY	1	
11	30500Z0DV02	IGNITION COIL ASSY	1.....	INCLUDES ITEMS W/ @
12@	30700Z0DV01	TERMINAL ASSY.	1	

HONDA GX100UKRBF ENGINE — CONTROL ASSY.

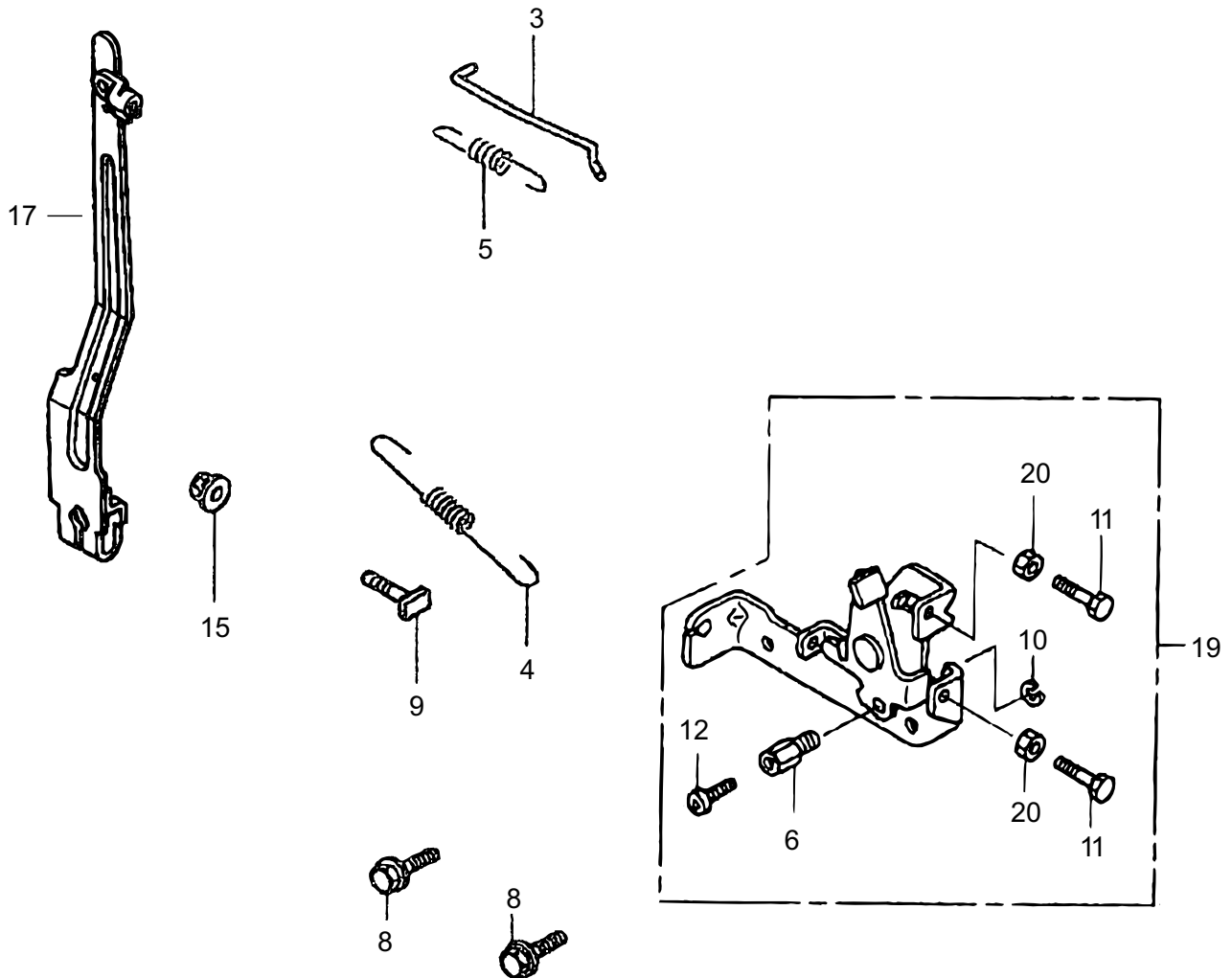

HONDA GX100UKRBF ENGINE — CONTROL ASSY.

CONTROL ASSY.

<u>NO.</u>	<u>PART NO.</u>	<u>PART NAME</u>	<u>QTY.</u>	<u>REMARKS</u>
3	16555Z0DV00	GOVERNOR ROD	1	
4	16561Z0DV00	GOVERNOR SPRING	1	
5	16562Z0DV00	SPRING, THROTTLE RETURN	1	
6@	16594883010	HOLDER, WIRE	1	
8	90014952000	VOLT, FLANGE 6X14 (CT200)	2	
9	90015ZE5010	BOLT, GOVERNOR ARM	1	
10@	90605230000	CIR CLIP	1	
11@	92301050200A	BOLT 5X20	1	
12@	93500040060H	SCREW 4X6	1	
15	94050060000	FLANGE NUT 6MM	1	
17	16550Z0DV01	GOVERNOR ARM	1	
19	16500Z4ES30	CONTROL ASSY	1.....	INCLUDES ITEMS W/ @
20@	94001050000	NUT M5	2	

HONDA GX100UKRBF ENGINE — LABELS ASSY.

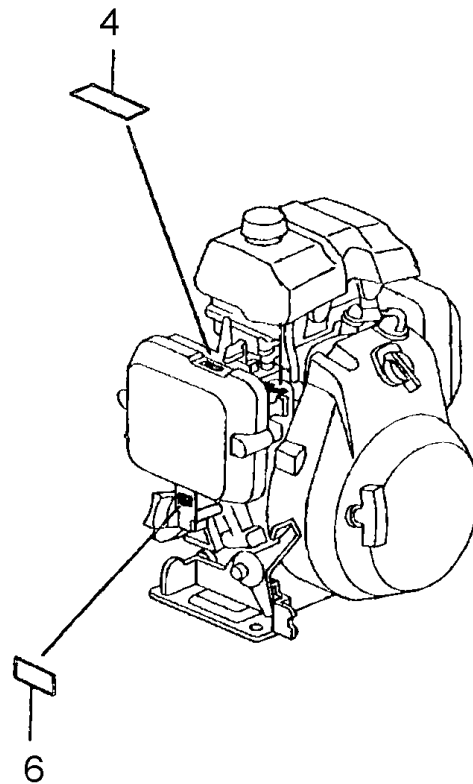
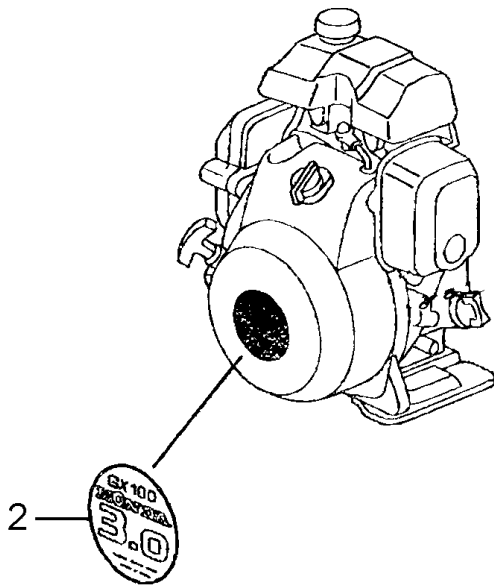
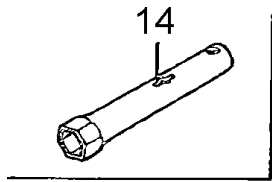

HONDA GX100UKRBF ENGINE — LABELS ASSY.

LABELS ASSY.

<u>NO.</u>	<u>PART NO.</u>	<u>PART NAME</u>	<u>QTY.</u>	<u>REMARKS</u>
2	87521Z0DV01	LABEL, TRADE MARK	1	
4	87528Z0D000	MARK, CHOKE	1	
6	87601Z4ES30	MARK, TYPE (KRBF)	1	
14	89216130690	WRENCH, SPARK PLUG	1	

TERMS AND CONDITIONS OF SALE — PARTS

PAYMENT TERMS

Terms of payment for parts are net 30 days.

FREIGHT POLICY

All parts orders will be shipped collect or prepaid with the charges added to the invoice. All shipments are F.O.B. point of origin. Multiquip's responsibility ceases when a signed manifest has been obtained from the carrier, and any claim for shortage or damage must be settled between the consignee and the carrier.

MINIMUM ORDER

The minimum charge for orders from Multiquip is \$15.00 net. Customers will be asked for instructions regarding handling of orders not meeting this requirement.

RETURNED GOODS POLICY

Return shipments will be accepted and credit will be allowed, subject to the following provisions:

1. A Returned Material Authorization must be approved by Multiquip prior to shipment.
2. To obtain a Return Material Authorization, a list must be provided to Multiquip Parts Sales that defines item numbers, quantities, and descriptions of the items to be returned.
 - a. The parts numbers and descriptions must match the current parts price list.
 - b. The list must be typed or computer generated.
 - c. The list must state the reason(s) for the return.
 - d. The list must reference the sales order(s) or invoice(s) under which the items were originally purchased.
 - e. The list must include the name and phone number of the person requesting the RMA.
3. A copy of the Return Material Authorization must accompany the return shipment.
4. Freight is at the sender's expense. All parts must be returned freight prepaid to Multiquip's designated receiving point.

5. Parts must be in new and resalable condition, in the original Multiquip package (if any), and with Multiquip part numbers clearly marked.
6. The following items are not returnable:
 - a. Obsolete parts. (If an item is in the price book and shows as being replaced by another item, it is obsolete.)
 - b. Any parts with a limited shelf life (such as gaskets, seals, "O" rings, and other rubber parts) that were purchased more than six months prior to the return date.
 - c. Any line item with an extended dealer net price of less than \$5.00.
 - d. Special order items.
 - e. Electrical components.
 - f. Paint, chemicals, and lubricants.
 - g. Decals and paper products.
 - h. Items purchased in kits.
7. The sender will be notified of any material received that is not acceptable.
8. Such material will be held for five working days from notification, pending instructions. If a reply is not received within five days, the material will be returned to the sender at his expense.
9. Credit on returned parts will be issued at dealer net price at time of the original purchase, less a 15% restocking charge.
10. In cases where an item is accepted, for which the original purchase document can not be determined, the price will be based on the list price that was effective twelve months prior to the RMA date.
11. Credit issued will be applied to future purchases only.

PRICING AND REBATES

Prices are subject to change without prior notice. Price changes are effective on a specific date and all orders received on or after that date will be billed at the revised price. Rebates for price declines and added charges for price increases will not be made for stock on hand at the time of any price change.

Multiquip reserves the right to quote and sell direct to Government agencies, and to Original Equipment Manufacturer accounts who use our products as integral parts of their own products.

SPECIAL EXPEDITING SERVICE

A \$35.00 surcharge will be added to the invoice for special handling including bus shipments, insured parcel post or in cases where Multiquip must personally deliver the parts to the carrier.

LIMITATIONS OF SELLER'S LIABILITY

Multiquip shall not be liable hereunder for damages in excess of the purchase price of the item with respect to which damages are claimed, and in no event shall Multiquip be liable for loss of profit or good will or for any other special, consequential or incidental damages.

LIMITATION OF WARRANTIES

No warranties, express or implied, are made in connection with the sale of parts or trade accessories nor as to any engine not manufactured by Multiquip. Such warranties made in connection with the sale of new, complete units are made exclusively by a statement of warranty packaged with such units, and Multiquip neither assumes nor authorizes any person to assume for it any other obligation or liability whatever in connection with the sale of its products. Apart from such written statement of warranty, there are no warranties, express, implied or statutory, which extend beyond the description of the products on the face hereof.

Effective: February 22, 2006

OPERATION AND PARTS MANUAL

HERE'S HOW TO GET HELP

PLEASE HAVE THE MODEL AND SERIAL
NUMBER ON-HAND WHEN CALLING

UNITED STATES

Multiquip Corporate Office

18910 Wilmington Ave. Tel. (800) 421-1244
Carson, CA 90746 Fax (800) 537-3927
Contact: mq@multiquip.com

Mayco Parts

800-306-2926 Fax: 800-672-7877
310-537-3700 Fax: 310-637-3284

Service Department

800-421-1244 Fax: 310-537-4259
310-537-3700

MQ Parts Department

800-427-1244 Fax: 800-672-7877
310-537-3700 Fax: 310-637-3284

Warranty Department

800-421-1244, Ext. 279 Fax: 310-537-1173
310-537-3700, Ext. 279

Technical Assistance

800-478-1244 Fax: 310-631-5032

MEXICO

MQ Cipsa

Carr. Fed. Mexico-Puebla KM 126.5 Tel: (52) 222-225-9900
Momoxpan, Cholula, Puebla 72760 Mexico Fax: (52) 222-285-0420
Contact: pmastretta@cipsa.com.mx

CANADA

Multiquip

4110 Industriel Boul. Tel: (450) 625-2244
Laval, Quebec, Canada H7L 6V3 Tel: (877) 963-4411
Contact: jmartin@multiquip.com Fax: (450) 625-8664

UNITED KINGDOM

Multiquip (UK) Limited Head Office

Unit 2, Northpoint Industrial Estate, Tel: 0161 339 2223
Global Lane, Fax: 0161 339 3226
Dukinfield, Cheshire SK16 4UJ
Contact: sales@multiquip.co.uk

© COPYRIGHT 2010, MULTIQUIP INC.

Multiquip Inc, the MQ logo and the Mikasa logo are registered trademarks of Multiquip Inc. and may not be used, reproduced, or altered without written permission. All other trademarks are the property of their respective owners and used with permission.

This manual MUST accompany the equipment at all times. This manual is considered a permanent part of the equipment and should remain with the unit if resold.

The information and specifications included in this publication were in effect at the time of approval for printing. Illustrations, descriptions, references and technical data contained in this manual are for guidance only and may not be considered as binding. Multiquip Inc. reserves the right to discontinue or change specifications, design or the information published in this publication at any time without notice and without incurring any obligations.

Your Local Dealer is:

