

CC300M MASONRY SAW

14"

Blade Capacity

Light Weight and Easy to Use

Moveable Head

Can Be Used To Bring the Blade Down on the Material or Locked to Push the Material Into the Blade

* Blade not included

Features/Benefits:

- The most cost-efficient way to cut masonry
- Cuts 5" deep with 14" blade
- Powerful 2 HP electric motor
- Durable frame design
- Tool-free air filter replacement
- Longer motor life due to a superior foam air filter
- Includes 2 spare air filters
- Smooth sliding material cutting table
- Cutting head is pulled down into the material

Specifications:

Power Supply:	115V/60Hz
Motor Power:	2 HP
Amp Draw:	15 amp
RPM:	3,600
Max. Depth of Cut:	5"
Max. Length of Cut:	16"
Material Capacity:	8" x 8" x 16"
Saw Height:	24" without stand
Saw Length:	28"
Saw Width:	23"

Masonry Blades can be found on

Pages 42-43

CC300M MASONRY SAW

Model #	Motor Type	Part #	Cat #	Blade Capacity	Uncrated/Crated Weight (lbs.)	List Price
CC300M	2 HP - 115 Volt 15 amp Electric	5800730	84807	14"	80/87	\$1,053

CC300M TRAY/CART ATTACHMENTS

Description	Part #	Cat #	List Price
Rip Guide	6043002	57689	\$39
180° Adjustable Angle Guide	6043004	57691	71

CC300M with Dust Collection Kit



CC300M with Wet Cut Kit

Wet cut kit Includes water pump



Connects to most shop vacuums, our pro collection vac and dustless systems



CC300M OPTIONS

Description	Part #	Cat #	List Price
Folding Stand for CC300M	6043056	84808	\$167
Wet Cut Kit for CC300M	6043058	90644	317
Dust Collection Kit for CC300M	6043057	84809	246

See our Dustless Products on Pages 261-264



Cost Efficient Masonry Cutting



* Blade not included



Masonry Blades
can be found on
Pages 42-43

Features/Benefits:

- The most cost-efficient way to cut pavers
- Powerful 2 HP electric motor
- Includes leg kit with 2 rear wheels
- Smooth sliding material cutting table
- Cutting head is pulled down into the material
- Cuts 4" deep with 14" blade
- Durable frame design with closed back
- Water pump included
- Water and material is contained in the heavy duty metal tray

CC350M MASONRY SAW

Model #	Motor Type	Part #	Cat #	Blade Capacity	Uncrated/Crated Weight (lbs.)	List Price
CC350M-E1	2 HP, 15 Amp 115V/60Hz Electric	5800731	98685	14"	178/193	\$1,184

Specifications:

Power Supply:	115V/60Hz or 220V/60Hz
Motor Power:	2 HP
Amp Draw:	15 or 7.5 amp
RPM:	3,600
Max. Depth of Cut:	5"
Max. Length of Cut:	16"
Material Capacity:	8" x 8" x 16"
Saw Height:	29" without leg kit 50-1/2" with leg kit
Saw Length:	48"
Saw Width:	24"
Weight:	178 lbs. with leg kit



Cutting head can be adjusted to cut at
45 or 90 degree angles

CC500MXLII MASONRY SAWS



Gasoline



Electric

14"

Blade Capacity

Part # 5800803



* Blade not included

Side Carrying Handles Are Standard

Parts Lists # 1800657 (CC500M)
1801098 (CC500MXLII)

Part # 5800814



Shown with optional folding stand

Masonry Blades can be found on Pages 42-43

Features:

- Variety of power options
- Stay level blade guard
- Removable cutting head
- Leg kit standard - folding stand optional
- Side carrying handles
- Includes water pump
- Vulcanized rubber coated material slide cart
- Open throat cutting

Benefits:

- Easy and safe access to depth control lock
- Open back cutting allows longer material to be cut
- Heavy duty frame design help resist damage to saw body
- Reinforced slide rails keep the cart running smoothly
- Simple yet strong design allows easy maintenance
- Sealed drain hole on the bottom of the tray allows quick clean up

MASONRY SAWS

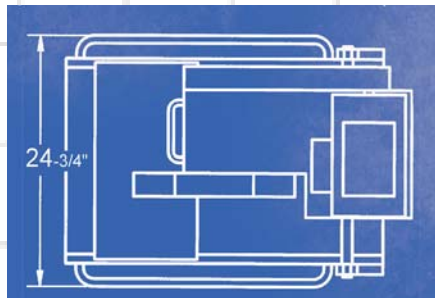
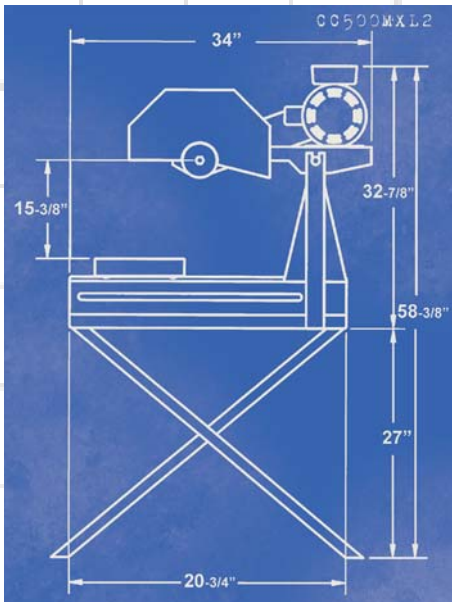

Folding Stand



Folding Stand with Wheel Kit

CC500MXLII MASONRY SAWS

Model #	Motor/Engine Type	Part #	Cat #	Blade Capacity	Uncrated/Crated Weight (lbs.)	List Price
CC515MXL2-E1	1.5 HP Baldor - 1PH-115/230V Electric	5800799	03725	14"	194/219	\$2,092
CC520MXL2-E1	2.0 HP Baldor - 1PH 115/230V Electric	5800814	08667	14"	195/220	2,137
CC525MXL2-E1	2.5 HP Baldor - 1PH-115/230V Electric	5800801	03726	14"	196/221	2,335
CC530MXL2-E1	3.0 Baldor-1PH 115/230V - 50 Hz Electric	5800802	03728	14"	205/230	2,360
CC555MXL2-H	5.5 Honda GX200 Gas	5800803	03732	14"	172/197	2,980
CC555MXL2-BV	5.5 HP Briggs & Stratton Gas	5801217	23961	14"	170/195	2,729
CC565MXL2-L	6.5 HP Lifan Gas	5801101	34008	14"	172/197	2,250

Specifications:

Maximum Depth of Cut:	5"
Blade Shaft Diameter:	7/8"
Arbor Diameter:	1"
Blade Shaft Bearings:	Flange block ball bearings
Blade Shaft Drive:	2 belt
Blade Mounting:	Right (electric), Left (gas)
Blade Raise/Lower:	Counterbalanced, spring tensioned head pivots on two 7/8" flange block bearings
Blade Coolant:	Dual spray tubes, pump fed (electric models), pump from tray (gas models)
Air Filter:	3-stage cyclone (gas models)
Fuel Capacity:	1 gallon (gas models)
High Temp Shut-off:	Included (electric models)

CC500MXLII OPTIONS

Description	Part #	Cat #	List Price
Folding Stand	2500839	46870	\$214
Folding Stand Upgrade*	6030042	46893	180
Folding Stand Wheel Kit	6030040	48547	86
Cord 50 ft. 12GA 115V 20A Twist to 15A Straight	4699100	47884	132
Cord 100 ft. 12GA 115 V 20A Twist to 15A Straight	4699101	48548	233
Emergency shut off button	6011615	27628	167

*Must be ordered with new saw to upgrade from the leg kit.

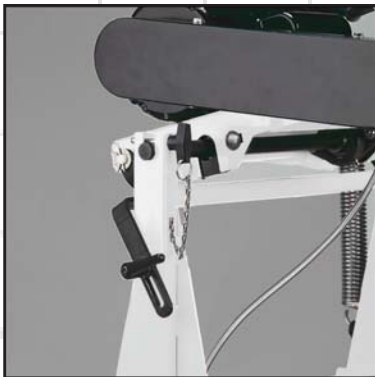

Removing the saw head is simple - just pull two locking pins and lift the head off of the frame. The cutting depth adjustment is on the side of the frame instead of the back.



The blade shaft and bearings are enclosed in a dust free housing to ensure long bearing life. The blade shaft cover plate allows easy access for greasing the bearings. The flange block bearings make bearing replacement easy without the need for a hydraulic press or other special tools.

As an option, the CC500MXLII can be fit with an emergency shut off button.

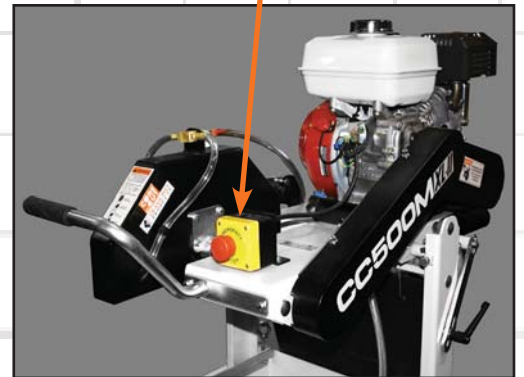

The stay-level blade guard provides the operator with safety and convenience while sawing. Our pivot mechanism resists slurry build-up, which could affect pivoting performance.

Low Amperage on Electric Models:

- 1.5HP Model Standard Draw 13.4 Amp - Perfect for House Power
- 2.0HP Model Standard Draw 15.8 Amp
- 2.5HP Model Standard Draw 21 Amp

CC800M BLOCK SAWS



Gasoline



Electric

24"

Blade Capacity



Features:

- 24" blade cuts a 10" block in a single pass
- Variety of power options
- Stay level blade guard and enclosed blade shaft
- Replaceable cart travel rails
- Durable 3/16" steel frame
- Includes water pump
- Easy rolling 16" x 25" aluminum cutting cart/tray with vulcanized rubber coated non-slip top
- Large capacity, deep tapered water tray

* Blade not included



Benefits:

- Foot pedal controlled operating head leaves the operators hands free to guide material
- Hand wheel for quick and easy blade cutting depth adjustment
- Enclosed cart wheels prevent damage
- Forklift opening for easy transport
- 2 V-belts promote efficient delivery of power to the blade
- Open back design for rip cutting longer materials
- Counterbalanced stay level blade guard assures the head is parallel to the cutting cart at all times

CC800M BLOCK SAWS

Model #	Motor/Engine Type	Part #	Cat #	Blade Capacity	Uncrated/Crated WEIGHT (lbs.)	List Price
CC850M-E1-20	5 HP - 1PH Electric	5800540	46820	20"	530/600	\$4,389
CC850M-E3-20	5 HP - 3PH Electric 230V	5800541A	96416	20"	550/620	4,495
CC850M-E3-20	5 HP - 3PH Electric 460V	5800541B	18533	20"	550/620	4,364
CC875M-E1-20	7.5 HP - 1PH Electric	5800542	47664	20"	560/630	4,603
CC875M-E3-20	7.5 HP - 3PH Electric 230V	5800544A	96015	20"	550/620	4,711
CC875M-E3-20	7.5 HP - 3PH Electric 460V	5800544B	96336	20"	550/620	4,574
CC875M-E1-24	7.5 HP - 1PH Electric	5800543	47630	24"	560/630	4,736
CC875M-E3-24	7.5 HP - 3PH Electric 230V	5800545A	97240	24"	550/620	4,847
CC875M-E3-24	7.5 HP - 3PH Electric 460V	5800545B	97000	24"	550/620	4,706
CC809H-20	8 HP GX270 Honda Gas	5800546	47024	20"	580/650	4,935
CC809L-20	9 HP Lifan Gas	5801107	33971	20"	576/645	4,250
CC813H-20	11 HP GX390 Honda Gas	5800547	47047	20"	600/670	5,208
CC813H-24	11 HP GX390 Honda Gas	5800548	47046	24"	600/670	5,348

Specifications:

Maximum Depth of Cut:	8" with 20" blade, 10" with 24" blade
Arbor Diameter:	1"
Blade Shaft Bearings:	Flange block ball bearings
Blade Shaft Drive:	2 premium gripnotch v-belt
Blade Raise/Lower:	Counterbalanced, spring tensioned head pivots on two 1" flange block bearings
Blade Coolant:	Dual spray tubes, pump fed (electric models), garden hose connection (gas models)
Air Filter:	3-stage cyclone (gas models)
Fuel Capacity:	1 gallon (gas models)
High Temp Shut-off:	Included (electric models)
Starter:	Recoil on gas models, capacity on electric models



Pedal mechanism is spring loaded, giving you more control of your cut

Hand wheel makes it easy to adjust your cutting depth

Foot pedal leaves the operator's hands free which helps safety issues when cutting

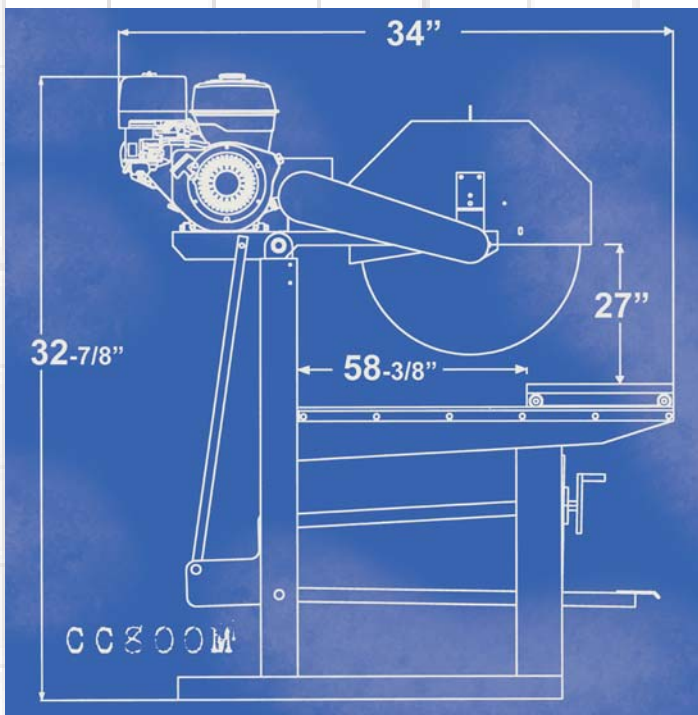

We offer 20" and 24" masonry blades to maximize your productivity when using the CC800M or any of the other masonry saw models.

Available in 5 different quality grades. See Pages 42-43 for more information.